

MJ11/MM11

TECHNICAL
INFORMATION
DEC CONFIDENTIAL

EP-MJ11-00-TI-A

COPYRIGHT © 1977

FICHE 1 OF 1

JAN 1977

digital

MADE IN USA

MJ11-A MM11

MM11-E

MM11-F

MM11-L

MM11-LP MM11-S

MM11-U/UP

TECH.
TIPS

DOL

DOL

FCR

ECO
QUICK
CHECK

DOL

ECO
QUICK
CHECK

FCR

ECO
QUICK
CHECK

FCO's

ECO
QUICK
CHECK

FCO's

ECO
QUICK
CHECK

FCO's

M J I A

MJ11-A

THE FOLLOWING MODULES/ASSEMBLIES ARE CONTAINED IN THIS DEVICE.
EACH MAY HAVE ASSOCIATED TECH TIPS, DEC-O-LOG AND FCO's DOCUMENTED
IN THE MODULE/ASSEMBLY CATEGORY OF THE MICROFICHE LIBRARY

G114	54-11086
G235	54-11553
	54-11581
	54-11583
H217	
H744	
H745	70-06501
	70-09769
M8148	70-10208
M8149	70-10214
	70-10497
	70-10498
	70-10532
	70-10580
	70-10581
	70-10694
	70-10695
	70-10780
	70-10791
	70-10824
	70-10826
	70-10974
	70-10975
	70-11027
	70-11222
	70-11223

M

M

I

I

THE FOLLOWING MODULE/ASSEMBLIES ARE CONTAINED IN THIS DEVICE. EACH MAY HAVE ASSOCIATED TECH TIPS,
DEC-O-LOG AND FCO'S DOCUMENTED IN THE MODULE/ASSEMBLY CATEGORY OF THE MICROFICHE LIBRARY.

70-06468
70-07263
70-09562

G102
G103
G109
G110
G225
G226
G231
G615
G616
G645

H213
H214

M109
M229
M1091
M7290

**TECH
TIPS**

digital	FIELD SERVICE TECHNICAL MANUAL				Option or Designator
	12 Bit <input type="checkbox"/>	16 Bit <input checked="" type="checkbox"/>	18 Bit <input type="checkbox"/>	36 Bit <input type="checkbox"/>	MM11

Title MM11 D/DP Memory Backplane				Tech Tip Number MM11-TT 14	
All	Processor Applicability	Author William Aupperley	Rev g	Cross Reference	
		Approval William Dimbar	Date 8-5 76		

The MM11-D/DP Core Memory Manual states that the G652 (mother board for the MM11-D/DP) is inserted into a "Unibus Backplane". To eliminate any confusion, the "Unibus Backplane" is the modified backplanes DD11-C, D and P used on 11/04, 11/34 systems. Other Unibus Backplanes, such as 11/05, 11/35 and DD-11B expansion backplanes are not compatible with these new memory boards.

PAGE 17	PAGE REVISION g	PUBLICATION DATE August, 1976
---------	-----------------	-------------------------------

digital	FIELD SERVICE TECHNICAL MANUAL				Option or Designator
	12 Bit <input type="checkbox"/>	16 Bit <input checked="" type="checkbox"/>	18 Bit <input type="checkbox"/>	36 Bit <input type="checkbox"/>	MM11

Title QUALADYNE 1540 SENSE AMPS				Tech Tip MM11 Number #1	
All	Processor Applicability		Author DON ZERESKI	Rev A	Cross Reference
			Approval CHUCK DEWEY	Date 6/27/72	

The Qualadyne 1540 sense amps have had bonding problems. The unit is used in most current DEC sense amplifier boards. The Motorola 1540 should be used as its replacement when necessary. Most of the defective units have been replaced during production. These were used in MM11-E and F memories.

Since the Motorola 1540 units are in short supply, Production is only replacing failing units and are not retrofitting all boards in all product lines. Machines in the field that exhibit strange memory problems that can be localized to sense amp problems should be checked for Qualadyne units with the following date codes: 7014, 7016, 7020, 7022, 7024, 7031, and 7032. These units may be defective and should be replaced as a last resort. We are not suggesting a purge of all Qualadyne units of the above mentioned date codes or future Qualadyne units.

Title H207E MEMORY STACK				Tech Tip MM11 Number #2	
All	Processor Applicability		Author TOM KARPOWSKI	Rev A	Cross Reference
			Approval CHUCK DEWEY	Date 6/27/72	

The MM11-E memory will be using a new stack, RCA's H207E. This stack can only be used in an MM11 E. The H207 stack can be used in an MM11-E and MM11 F.

Title MM11-E & F/G102 MODULES				Tech Tip MM11 Number #3	
All	Processor Applicability		Author TOM KARPOWSKI	Rev B	Cross Reference
			Approval CHUCK DEWEY	Date 6/1/72	

ECO G102-00005 has been written to make the G102 module capable of running in the MM11 F memory. This ECO makes this module CS revision D. It has to be at least revision D to run in an MM11-F. This revision can also be used in MM11-E's. Please see that your spares are modified accordingly.

Title INTERLEAVING THE MM11-E MEMORY				Tech Tip MM11 Number #4	
All	Processor Applicability		Author JOHN BUZYNSKI	Rev g	Cross Reference
			Approval CHUCK DEWEY	Date 6/1/72	

Interleaving is simply addressing the memory such that adjacent memory banks are selected on alternate cycles. Thus, it is interleavable in 8K increments or blocks. This is implemented by interchanging BUS A01L and BUS A13L inputs to the memory between the bus inputs and memory device select and control. The memory being addressed, for example, in a DAT1 mode is free to complete its cycle after the MSYN L-SSYN I dialog and as soon as the setup times for the bus are satisfied, MSYN L can be reasserted to

Title INTERLEAVING THE MM11-E MEMORY (Continued)				Tech Tip MM11 Number #4	
All	Processor Applicability			Author JOHN BUZYNSKI	Rev 0
				Approval CHUCK DEWEY	Date 6/1/72
Cross Reference					

start a memory cycle in the adjacent memory bank while the first memory bank is completing its cycle. A significant increase in memory throughput occurs.

In the MM11-E the two address bits have to be physically interchanged on the back plane. It is also necessary to modify M729 control logic module to speed up the SSYNL reset circuit. (Refer to ECO's MM11-E Numbers 17, 19, and 20; M729 number 2; and ECO M1091 number 1).

Remember, when troubleshooting an interleaved memory, that successive addresses reference alternate memory banks.

Title FIELD INSTALLATION OF MM11-E ON PDP-11/45				Tech Tip MM11 Number #5	
All	Processor Applicability			Author ANDY VEROSTIC	Rev 0
	11/45			Approval ART ZINS	Date 6/7/72
Cross Reference					

HARDWARE

Existing M729 control must have ECO #M729-00003 installed for operation on 11/45.

DIAGNOSTICS

All present memory tests will run on the 11/45.

Title FIELD INSTALLATION OF MM11-F ON PDP-11/45				Tech Tip MM11 Number #6	
All	Processor Applicability			Author ANDY VEROSTIC	Rev A
	11/45			Approval ART ZINS	Date 6/7/72
Cross Reference					

HARDWARE

Existing M7290 control must have ECO's #M7290-00002 and 00003 installed for proper operation on the 11/45.

DIAGNOSTICS

All present memory tests run on the 11/45.

digital	FIELD SERVICE TECHNICAL MANUAL				Option or Designator
	12 Bit <input type="checkbox"/>	16 Bit <input checked="" type="checkbox"/>	18 Bit <input type="checkbox"/>	36 Bit <input type="checkbox"/>	MM11

Title MM11-E and F MEMORY ADDRESS SELECTION AND INTERLEAVING			Tech Tip MM11 TT Number #7		
All	Processor Applicability	Author	Chuck Dewey	Rev	0
		Approval	Chuck Dewey	Date	9/28/72
Cross Reference					

Address Selection

MM11-E Memories have had two types of address selection modules. The M109 was the original address selector and may still be found in some installations. The M109 causes insertion of two UNIBUS unit loads. This was corrected when the M1091 was introduced (ECO M1091-00001). Selection of addresses when using M109 is described in the hardware manual (DEC-11-HR3B-D).

Both the MM11-E and MM11-F memories now utilize M1091 address selector modules. Figure 2 shows the circuit schematic of the M1091 address selection logic. Figure 1 shows a layout of that portion of the physical module where the addressing is accomplished by insertion or removal of jumper wires. Table 1 lists the following:

- a. Bank Number - These numbers are indicative of the physical system units of MM11-F or F memories.
- b. K Words - This indicates the word quantity for a specific bank in thousands (K) words.
- c. Addresses - The inclusive (octal) word (two byte) addresses within a specific bank of memory are listed here. They assume a non-interleaved configuration.
- d. Bits 17, 16, 15, 14, 13 and 01 Non-Interleaved - These columns show, by an X, that jumper which should be installed in order to respond to a specific memory bank addressing. The 1, 0, A, B, C and D correspond to the identification shown on the module, figure 1, and figure 2.
- e. Bits 13, and 01 Interleaved - These two bits accomplish the interleaving for MM11-F memories and are to be used in place of their counterparts listed for d, above. When used these cause modification of two 4K Banks so that their addressing has the lower (odd) bank with addresses ending with 0 or 4 and upper (even) bank ending with 2 or 6.

Title MM11-E and F MEMORY ADDRESS SELECTION AND INTERLEAVING		Tech Tip Number MM11 TT #7	
All	Processor Applicability	Author Chuck Dewey	Rev V
		Approval Chuck Dewey	Date 9/28/72
			Cross Reference

Interleaving

Interleaving for MM11-E memories is described in Tech Tip MM11 number 4. It can only be accomplished by system unit wire changes to the back plane. Refer to the ECO's, listed in the Tech Tip, for proper implementation.

MM11-F interleaving is accomplished by manipulation of jumper wires on the M1091 module. These changes are shown in Table 1. It is a normal procedure for the production line to interleave all 8K segments of MM11-F memory on the initial system prior to shipment.

Interleaving of a MM11-E with an MM11-F is not recommended primarily due to the confusion it creates when troubleshooting a system of this nature. It also creates customer misunderstanding since the average memory cycle time specification, in this situation, would not be either the MM11-E or F but somewhere in between.

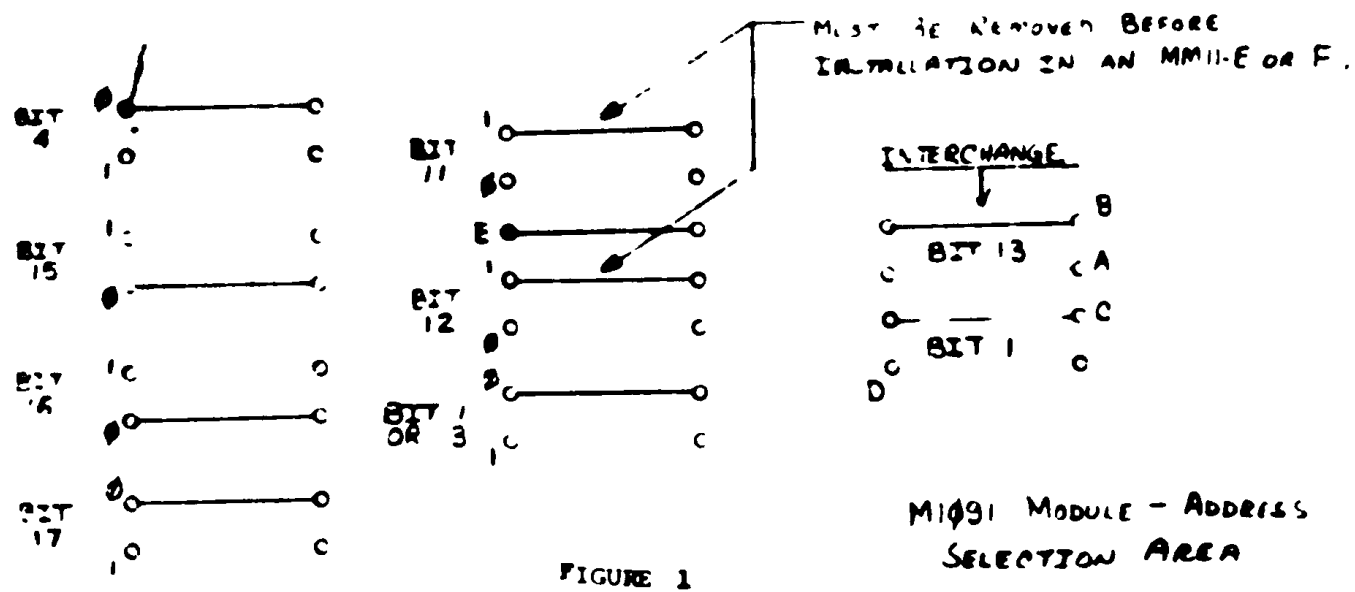

Title MM11-E and F MEMORY ADDRESS SELECTION & INTERLEAVING (CONT'D)	Tech Tip MM11 TT Number 07
Processor Applicability All <input type="checkbox"/> <input type="checkbox"/> <input type="checkbox"/> <input type="checkbox"/> <input type="checkbox"/> <input type="checkbox"/> <input type="checkbox"/> <input type="checkbox"/> <input type="checkbox"/> <input type="checkbox"/>	Author Chuck Dewey Rev g Approval Chuck Dewey Date 9/28/72
Cross Reference	

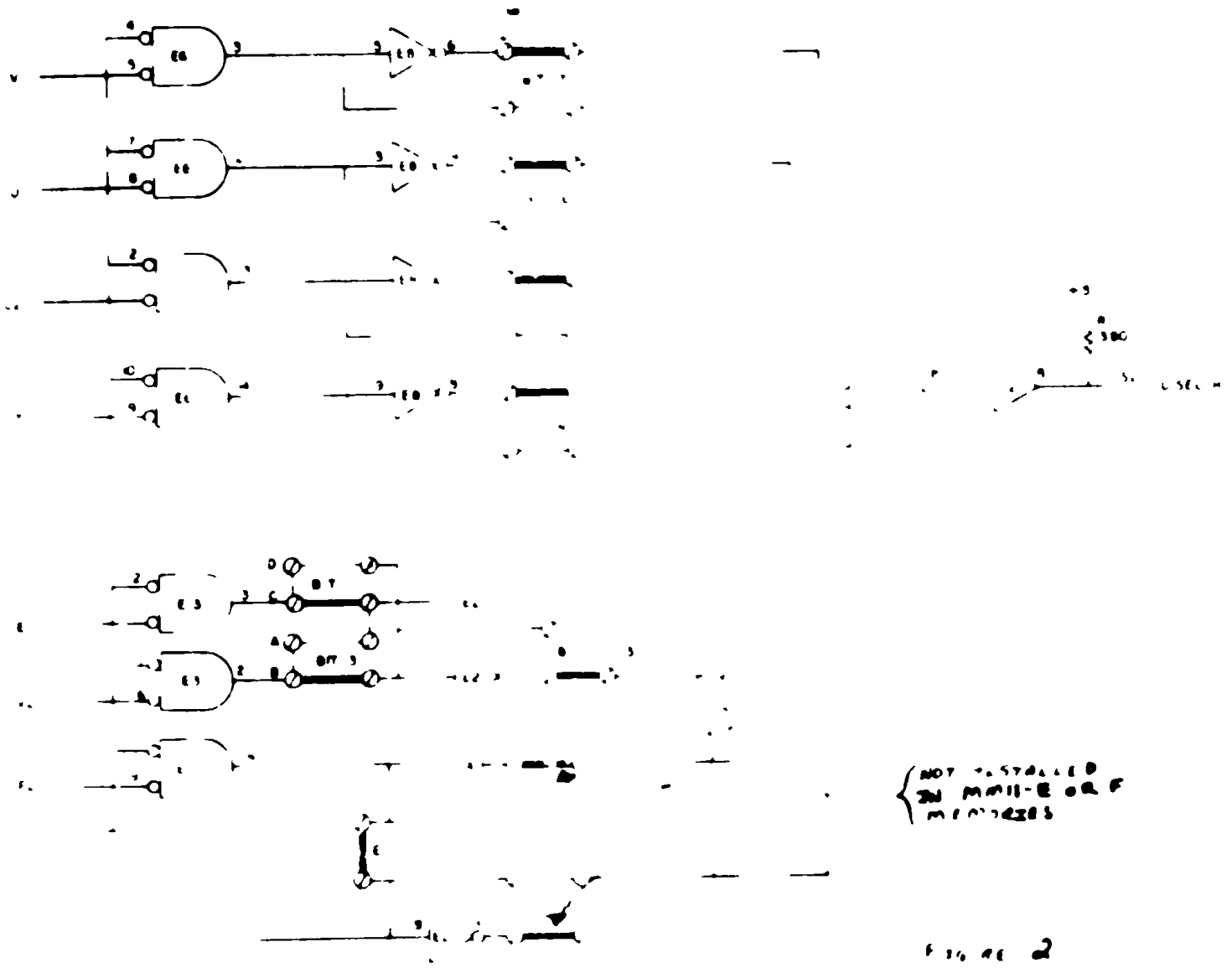

Title MM11-E and F MEMORY ADDRESS SELECTION & INTERLEAVING (CONT'D)				Tech Tip MM11 TT Number 07	
Processor Applicability		Author Chuck Dewey		Rev #	
All		Approval Chuck Dewey		Date 9/28/72	
Cross Reference					

TABLE 1

Line	K WORDS	ADDRESSES		NON-INTERLEAVED MM11-F AND ALL MM11-E MEMORIES								INTERLEAVED MM11-F MEMORY *						
		FROM	TO	17	16	15	14	13	01			3	01					
				1	0	1	0	1	0	A	B	C	D	A	B	C	D	
1	0-4	000000	017776	X	X	X	X	X	X	X	X	X	X	X	X	X	X	
2	4-8	020000	037776	X	X	X	X	X	X	X	X	X	X	X	X	X	X	
3	8-12	040000	057776	X	X	X	X	X	X	X	X	X	X	X	X	X	X	
4	12-16	060000	077776	X	X	X	X	X	X	X	X	X	X	X	X	X	X	
5	16-20	100000	117776	X	X	X	X	X	X	X	X	X	X	X	X	X	X	
6	20-24	120000	137776	X	X	X	X	X	X	X	X	X	X	X	X	X	X	
7	24-28	140000	157776	X	X	X	X	X	X	X	X	X	X	X	X	X	X	
FROM THIS POINT ON A DEVICE SUCH AS MX11, KS11, OR KT11 IS REQUIRED																		
8	28-32	160000	177776	X	X	X	X	X	X	X	X	X	X	X	X	X	X	
9	32-36	200000	217776	X	X	X	X	X	X	X	X	X	X	X	X	X	X	
10	36-40	220000	237776	X	X	X	X	X	X	X	X	X	X	X	X	X	X	
11	40-44	240000	257776	X	X	X	X	X	X	X	X	X	X	X	X	X	X	
12	44-48	260000	277776	X	X	X	X	X	X	X	X	X	X	X	X	X	X	
13	48-52	300000	317776	X	X	X	X	X	X	X	X	X	X	X	X	X	X	
14	52-56	320000	337776	X	X	X	X	X	X	X	X	X	X	X	X	X	X	
15	56-60	340000	357776	X	X	X	X	X	X	X	X	X	X	X	X	X	X	
16	60-64	360000	377776	X	X	X	X	X	X	X	X	X	X	X	X	X	X	
17	64-68	400000	417776	X	X	X	X	X	X	X	X	X	X	X	X	X	X	
18	68-72	420000	437776	X	X	X	X	X	X	X	X	X	X	X	X	X	X	
19	72-76	440000	457776	X	X	X	X	X	X	X	X	X	X	X	X	X	X	
20	76-80	460000	477776	X	X	X	X	X	X	X	X	X	X	X	X	X	X	
21	80-84	500000	517776	X	X	X	X	X	X	X	X	X	X	X	X	X	X	
22	84-88	520000	537776	X	X	X	X	X	X	X	X	X	X	X	X	X	X	
REQUIRED FROM THIS POINT IF DEVICE IS IN USE																		
23	88-92	540000	557776	X	X	X	X	X	X	X	X	X	X	X	X	X	X	
24	92-96	560000	577776	X	X	X	X	X	X	X	X	X	X	X	X	X	X	
25	96-100	600000	617776	X	X	X	X	X	X	X	X	X	X	X	X	X	X	
26	100-104	620000	637776	X	X	X	X	X	X	X	X	X	X	X	X	X	X	
27	104-108	640000	657776	X	X	X	X	X	X	X	X	X	X	X	X	X	X	
28	108-112	660000	677776	X	X	X	X	X	X	X	X	X	X	X	X	X	X	
29	112-116	700000	717776	X	X	X	X	X	X	X	X	X	X	X	X	X	X	
30	116-120	720000	737776	X	X	X	X	X	X	X	X	X	X	X	X	X	X	
31	120-124	740000	757776	X	X	X	X	X	X	X	X	X	X	X	X	X	X	

8.5 ADDRESSING BEYOND THIS POINT - RESERVED FOR DEVICES

X DENOTES JUMPER INSERTION ON THE BOARD AT THE IDENTIFIED POINT

* INTERLEAVING CAN ONLY BE ACCOMPLISHED WITH 8K SEGMENTS OF MEMORY. THE XXXX0 AND XXXX4 ADDRESSES ARE TO BE ASSIGNED TO ODD BANK MEMORIES

digital	FIELD SERVICE TECHNICAL MANUAL				Option or Designator
	12 Bit <input type="checkbox"/>	16 Bit <input type="checkbox"/>	18 Bit <input type="checkbox"/>	36 Bit <input type="checkbox"/>	

Title				Tech Tip Number	
AN				Cross Reference	
Processor Applicability		Author		Rev	
Approval		Date			

Problem exist with the 4K-8K PDP-11 memory (PM11-S, PM11, PM11-L) that appear to be hardware data error, but disappears if every word in memory is accessed. The problem was observed whenever Initialize or DCL0 occurs during a memory cycle. This turns off the B-Y current drivers at the wrong time, leaving some cores in a partially switched state. These half-selected cores contribute large amounts of noise when accessing other words, causing intermittent failures.

ALC occurring during a memory cycle can be eliminated if the power fail trap is used properly. The power fail trap sequence should turn off any peripheral that writes to core memory (individually, not by using INIT) and halt the processor before DCL0 or

The chances of INIT occurring during a memory cycle will be reduced if software avoids using the RESET instruction, particularly inside tight loops. The condition of half selected cores can be cured by accessing every word in memory to assure all cores are fully switched. Once this is completed, data may be read and written normally.

Title		Tech Tip # 11	
MM11-A, L, M, and C Field Problem Summary		Number TT 1	
All	Processor Applicability	Author D. Dickhut	Rev 1
		Approval C. Dewey	Date 11/20/72
Cross Reference			

This Tech Tip is a summary of field problems and their solutions for the MM11-A, L, M, and C memories which are found in MM11L which uses only MM11-L, 11/05 and 11/10 which use MM11-L (4K 11/05 only and MM11-L (8K 11/40 which uses only MM11-L (8K), and 11/45 which uses only MM11-L (8K).

1. Random Memory Locations are Altered During Power Fail

The contents may be altered while running Power Fail Diagnostic or by simply turning the machine on and off. ECO G231-5 solves this problem.

2. Memories to not have to be swapped as a system (all 3 modules)

Each system that is shipped has a serial number stamped on side 2 of each module. This number is the same on all 3 modules and is strictly for in-house test purposes only. The memories can be and should be maintained on a module swap basis instead of a system basis (stack not used anyway). The system serial number can be used in a case where such swapping has taken place and now the modules are to be put back in their original configuration. By matching the serial number, each system can be reunited and a lot of adjustment time can be saved.

3. What adjustments to make when a module is swapped.

When anyone of the 3 modules that make up the memory system is swapped, the strobe adjustment must be made to ensure system reliability (When the G110 module is swapped, it has the strobe pot but the setting cannot be taken for granted) The procedure to use for strobe adjustment is as follows:

1. If strobe adjustment is too far off, EXAM and L&P may not work. To get strobe in the ballpark, sync on pin CU2 of the G110 module (signal READ H) and Test Point 5 of E05 pin 9 for strobe. Press EXAM rapidly and adjust strobe using pot on G110 for a 250 ns delay from rising edge of READ H to rising edge of strobe. This should allow diagnostics to be read in.
2. Load Worst Case Noise Diagnostic (W.C.N. should be used not a Branch DLP)
 1. Load Address 200 and START or Load Address 202 to select the desired bank.
4. Sync on pin CU2 of G110 (signal READ H) while scoping Test Point 5 or F05. Adjust for strobe and margin strobe by turning pot CW until the diagnostic fails and then CCW until it fails. A complete pass of the diagnostic should be made (within reasonable limits for large core systems) at each high and low end point to ensure that is the true end point. Notice the time from the leading edge of READ H to strobe in each case. The total strobe window should be 40 ns or greater and set strobe in the middle of the high and low points. If the window isn't at least 40 ns, then the entire system should be changed because margin problems can only be dealt with back at Module Repair Dept.

This procedure is graphically illustrated and explained in the MM11L, MM11-L, 11/05, and 11/40 manuals.

digital	FIELD SERVICE TECHNICAL MANUAL				Option or Designator
	12 Bit <input type="checkbox"/>	16 Bit <input checked="" type="checkbox"/>	18 Bit <input type="checkbox"/>	36 Bit <input type="checkbox"/>	4M 1

Title: MM1-R, L, M, and S Field Problem Query				Tech Tip Number	4M 1
Processor Applicability		Author	Rev	Cross Reference	
All					
Approval		Date	11.10.71		

4. DEC memory stack threshold problem

Some DEC or RCA memory stacks (DEC stack identified by label on side 2; some may have RCA stickers) have a threshold problem and will not exhibit the normal threshold margins. In order to use these previously rejected stacks in production, the sense circuitry on the G110 was modified. In the field, if a memory stack is swapped and it is a DEC stack, the G110 module should be checked to see if P1008 is installed. If it isn't and this is a non-field effect (i.e., a G110 module with that ECU should be obtained from the Maynard Module Repair Dept). The new DEC stack may or may not have this problem and probably will operate properly even if it does. However, with large systems or several NIK (LMA) devices, intermittent failures may occur over a long period of time.

Title				Tech Tip Number		44	
All				Author G. Cable		Rev #	
Processor Applicability				Approval C. Dewey		Date 12/12/72	
						Cross Reference	

The following Tech Tip will attempt to clarify the confusion regarding the ECO status for MM11, MM11F and MM11L memories.

J.M. D.

In the near future there will be two separate types of G110 Modules in the field. The first type of G110 Module is an Etch Revision C Module which already exists in the field. The second type of module will be an Etch Revision E.

It will not be possible to ECO the Etch Revision C Module so that it will be electrically equal to the Etch Revision E Module. For this reason it has become necessary to create two separate sets of engineering drawings to cover the two different modules.

The engineering drawings for the Etch Revision C Module will have a circuit schematic revision of E with one numeric digit following. Each ECO released will increment the numeric digit by one (i.e. E1, E2, E3, and etc.).

The engineering drawings for the Etch Revision E Module will have a circuit schematic revision of H with an alpha character starting at F and continuing sequentially (i.e. F, H, J, K, and etc.).

Below is a chart that shows the revisions for the two G110 Modules.

G110 Etch Revision C	
ECO No.	CS Revision
G110-0001	A
G110-0002	B
G110-0003	N/A
G110-0003A	N/A
G110-0004	D
G110-0005	L
G110-0007	E-1
G110-0008	E-2
G110-0009	E-3*
G110-0010	E-4*
G110-0011	E-5

G110 Etch Revision E	
ECO No.	CS Revision
G110-0006	F
G110-0011	H

*Note: There have been a number of Etch Revision C modules shipped that were marked Rev H and J there should have been marked as Rev E3 and E4 respectively.

digital	FIELD SERVICE TECHNICAL MANUAL				Option or Designator
	12 Bit <input type="checkbox"/>	16 Bit <input checked="" type="checkbox"/>	18 Bit <input type="checkbox"/>	36 Bit <input type="checkbox"/>	MM11

Title ECO DOCUMENTATION FOR THE MM11K, MM11L and MM11S Memories (Continued)			Tech Tip Number MM11 TT 10
All	Processor Applicability	Author G. Cable	Rev g
x		Approval C. Dewey	Date 12/12/72

G231 Module

There will also be two separate types of G231 Modules in the field in the near future. For this reason it has become necessary to create two sets of engineering drawings.

The first type of G231 Module will be an Etch Revision of C. All future ECO's for this module will use a circuit schematic revision of E with a numeric digit following. Each ECO released will increment the numeric digit by one (i.e. E4, E5, E6 and etc.).

The second type of G231 Module will be an Etch Revision of E. All future ECO's for this module will use a circuit schematic revision with only an alpha character as a designator starting at CS Revision F and incrementing thru the alphabet (i.e. F, H, J, K, and etc.).

Below is a chart that shows the revisions for the two G231 Modules.

G231 Etch Revision C			G231 Etch Revision E	
ECO No.	CS Revision	Stamped on Module	ECO No.	CS Revision
G231-0001	C	C	G231-0004	F
G231-0002	N/A	N/A		
G231-0003	C-1	E		
G231-0005	1	E-1		
G231-0006	2	E-2		
G231-0007	3	3		
G231-0008	3A	3A		
G231-0009	E4	E4		

Refer to PDP 11/05 Systems Tech Tip #14 for a detailed listing and description of memory ECO's.

Title				Tech Tip	
New MM11 Option Designations				Number	
				MM11 TT-11	
All	Processor Applicability		Author	Rev	Cross Reference
			D. Dickhut	1	
		Approval	Date		
		C. Dewey	1/19/73		

This tech tip is to define the new variations of memories that are in existence and how they differ from the present MM11-L and S memories. The MM11-L and S are defined again for reference.

MM11-L (8K X 16, 900 ns)

It consists of a G110, G231 and H214 and is used on 11/05, 11/10, ME11-L and 11/40.

MM11-S (8K X 16, 900 ns)

This consists of a G110, G231, H214, and a system unit. It is used on 11/35, 11/40 to 11/45.

MM11-LP (8K X 18, memory parity)

This consists of a G109, G231 and H215 and is designed for memory parity. It plugs into a MF11-LP.

MF11-LP (Parity Option)

This is a memory parity option that consists of a nine slot backplane, one MM11-LP and one M7259 double height double width memory parity controller. The backplane can accommodate three MM11-LP's. This option is used on 11/35, 11/40 and 11/45.

MF11-L

This is a memory option that consists of a nine slot backplane and one MM11-L. It can accommodate three MM11-L and is used on 11/35, 11/40 and 11/45.

MB11-S (8K X 16)

This is a special 8K X 16 memory with a 850 ns cycle time and consists of a G110-YA, G231, and H214-YA. This memory is used only on 11/45 and exists in very limited quantities.

G109-YA (for reference only)

Module used only on PDP15 memories.

It is important to remember that the modules mentioned in the above definitions are not interchangeable with a similar looking type in another category. For example a G109 is not interchangeable with a G110 nor is a G110 interchangeable with a G110-YA. When a memory module is replaced or swapped, it should only be replaced with the exact same module type, even though another type may appear to work.

digital	FIELD SERVICE TECHNICAL MANUAL				Option or Designator
	12 Bit <input type="checkbox"/>	16 Bit <input checked="" type="checkbox"/>	18 Bit <input type="checkbox"/>	36 Bit <input type="checkbox"/>	MM 11

Title MM11- E and F in BA11-B/D/F Mounting Boxes				Tech Tip MM11-TT-12 Number	
All	Processor Applicability		Author B. Dimbat	Rev 0	Cross Reference
			Approval C. Dewey	Date 3/14/73	

MM11E and MM11F memories cannot be installed in the 11/40 box. They cannot be installed in BA11-B/D/F boxes. They can be used on the 11/40 system but only if they are installed in an 11/20 type box (BA11-ES), which has its own power supply.

MM11E/F's, installed in an 11/40 box, will lose data during the power down sequence.

Title MM1L, S & K Memory Address Decode		Tech Tip Number MM FI 1	
All	Processor Applicability	Author John Alston	Rev 0
		Approval B. Dimbat	Date 6/1/73
Cross Reference			

The diagram and tables supplied here are to aid F/S men when they are troubleshooting MM1L, S & K memories by relating the drive signals on the G231 with the addresses that generate them.

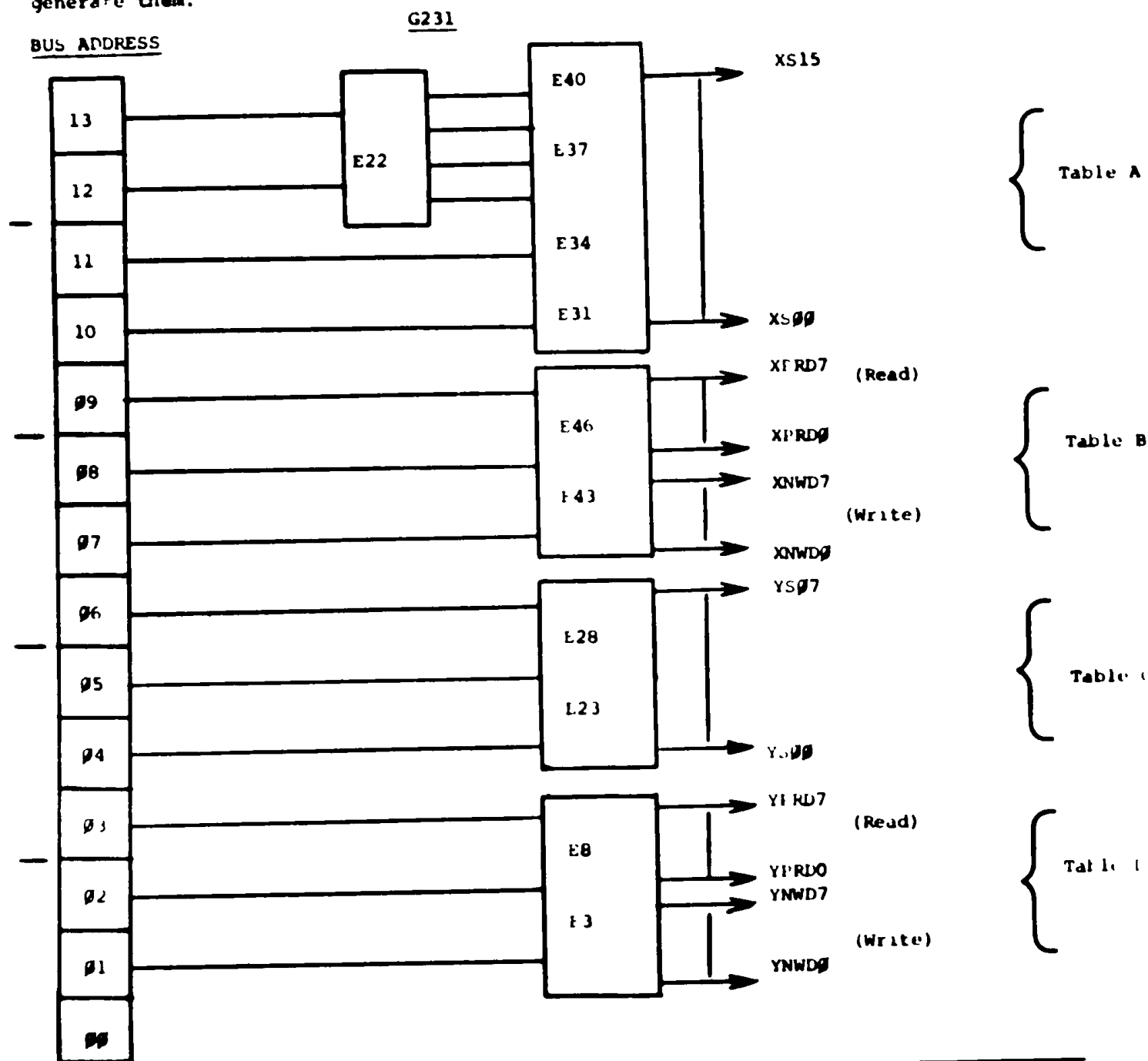

digital	FIELD SERVICE TECHNICAL MANUAL				Option or Designator
	12 Bit <input type="checkbox"/>	16 Bit <input checked="" type="checkbox"/>	18 Bit <input type="checkbox"/>	36 Bit <input type="checkbox"/>	MM11

Title MM11 I, S, F Memory Address Decode				Tech Tip Number MM11-TT-13	
All Processor Applicability		Author J. Alston	Rev 0	Cross Reference	
		Approval B. Dimbat	Date 6/1/73		

	A11=1, A10=1	A11=1, A10=0	A11=0, A10=1	A10=0, A11=0
A13=1 A12=1	XS15	XS14	XS13	XS12
	E40			
A13=1 A12=0	XS11	XS10	XS09	XS08
	E37			
A13=0 A12=1	XS07	XS06	XS05	XS04
	E34			
A13=0 A12=0	XS03	XS02	XS01	XS00
	E31			

TABLE A

	A08=1, A07=1	A08=1, A07=0	A08=0, A07=1	A08=0, A07=0
Read Cyc. A09=1	XPRD7	XPRD6	XPRD5	XPRD4
	E46			
A09=0	XPRD3	XPRD2	XPRD1	XPRD0
	E43			
Write A09=1	XNWD7	XNWD6	XNWD5	XNWD4
	E46			
A09=0	XNWD3	XNWD2	XNWD1	XNWD0
	E43			

TABLE B

Title		M11, 1, S, K Memory Address Decode		Tech Tip Number		MM-TT-13	
All	Processor Applicability			Author	J. Alston	Rev	0
				Approval	E. Dimbat	Date	6/1/73
Cross Reference							

TABLE C

	A5=1, A04=1	A05=1, A04=0	A05=0, A04=1	A05=0, A04=0
A06=1	YS07	YS06	YS05	YS04
	E28			
A06=0	YS03	YS02	YS01	YS00
	E23			

TABLE D

		A02=1, A01=1	A02=1, A01=0	A02=0, A01=1	A02=0, A01=0
read	A03=1	YPRD7	YPRD6	YPRD5	YPRD4
		E8			
	A03=0	YPRD3	YPRD2	YPRD1	YPRD0
		E3			
write	A03=1	YNWD7	YNWD6	YNWD5	YNWD4
		E8			
	A03=0	YNWD3	YNWD2	YNWD1	YNWD0
		E3			

MMMIIE

MM11-E/F PARTS BREAKDOWN

7006405	- Logic Frame
7006468	- MM11-E Wired assembly
70007263	- MM11-F Wired assembly
G102	- Sense Inhibit Card
G103	- Memory Levels & Gates
G225	- X-Y Current Generator
G226	- X-Y Current Generator
H207	- 4K 16 Bit Core Memory Stack
M109	- Device Select
M729	- MM11-E Control Logic
M1091	- Device Select
M7290	- Control Logic & Timing
MM11-E	- 4K Single Memory Unit
MM11 EX	- 4K Interleaved
MM11-I	- 4K Single Memory Unit
MM11-FP	- Single Parity Memory Unit
MM11-FX	- Interleaved Memory (jumpers)

DOLL

Engineering Change Order Log

DEC-O-LOG

ECO SYNOPSIS pages are updated and published continuously in conjunction with the issuance of ENGINEERING CHANGE ORDERS for all DEC products and are available upon subscription from:

DIGITAL EQUIPMENT CORPORATION
FIELD SERVICE INFORMATION CENTER
MAYNARD MASSACHUSETTS 01754

digital EQUIPMENT CORPORATION
MAYNARD MASSACHUSETTS

ECO SYNOPSIS FOR LOGIC OR OPTION

PDP-11 MEMORY **MMII-E**

PRODUCT LINE	PUBLICATION DATE OF THIS SYNOPSIS PAGE	PAGE REVISION
PDP-11	JULY 1975	0

ECO NO	LOGIC OR OPTION SERIAL NO S AFFECTED	FIELD CODE	SYNOPSIS
MMII-E 0000	>MMII-E	M	JAN 70 - CHANGES STACK HINGE TOLERANCE AND ADDS A FLATNESS SPECIFICATION.
MMII-E 0002	MMII-E 110-170	D	JAN 70 - MAKES CORRECTIONS TO THE WIRE LIST.
MMII-E 0003	MMII-E 110-120	D	JAN 70 - ADDS CURRENT LOOPS FOR X AND Y CURRENT MEASUREMENTS AND SCOPING. UPDATES THE LIST OF MANUALLY INSTALLED WIRING.
MMII-E 0004	>MMII	D	JAN 70 - UPDATES THE MMII-E PRINT SET.
MMII-E 0005	N.A.	D	JAN 70 - CORRECTS A DRAWING WHICH WAS DRAWN IN REVERSE. ADDS CLARIFICATION NOTES.
MMII-E 0006	MMII-E 110-239	D	FEB 70 - ADDS TWO WIRES WHICH WERE PREVIOUSLY OMITTED FROM THE WIRE LIST.
MMII-E 0007	>MMII-E	M	FEB 70 - CHANGES THE SPECIFICATION FOR THE MEMORY HINGE. SPECIFIES THE USE OF SELF EXTINGUISHING PLASTIC FOR MMII-E FABRICATION.
M729 0001	ALL M729	B	MAR 70 - REVISES SEVERAL DESIGN CONSIDERATIONS; CHANGES THE ETCH LAYOUT AND SEVERAL COMPONENTS. MODULE STATUS - UNRELEASED. M729 CIRCUIT SCHEMATIC REVISION A ETCHED BOARD REVISION B
G226 0003	>G226	B	MAR 70 - ADDS DIODES TO CLAMP OUTPUT VOLTAGE SPIRES WHICH COULD EXCEED THE TRANSISTOR BREAKDOWN RATINGS. MODULE STATUS - UNRELEASED. G226 CIRCUIT SCHEMATIC REVISION C

ECO NO	LOGIC OR OPTION SERIAL NO S AFFECTED	FIELD CODE	SYNOPSIS
G102 0002	>PDP-11	F	MAR 70 - REPLACES THE 8881 IC WITH A 74HC11 TO INCREASE SPEED. THIS MODULE CANNOT BE REWORKED IN THE FIELD. (ERROR CORRECTED BY ECO G102-0003) G102 CIRCUIT SCHEMATIC REVISION B ETCHED BOARD REVISION D
G103 0002	ALL PDP-11	F	MAR 70 - REPLACES SM7410M IC WITH SM7410N TO INCREASE SYSTEM SPEED. THE MODULE CANNOT BE REWORKED IN THE FIELD. G103 CIRCUIT SCHEMATIC REVISION B
G102 0003	>PDP-11	F	APR 70 - CORRECTS AN ERROR IN ECO G102-0002; CHANGES 100 OHM RESISTORS TO 75 OHMS. G102 CIRCUIT SCHEMATIC REVISION B ETCHED BOARD REVISION D
MMII-E 0008	>MMII-E	P	APR 70 - CORRECTS DIMENSIONS ON THE ETCHED BOARD DRAWING TO MEET STANDARDS.
MMII-E 0009	N.A.	P	APR 70 - CHANGES WIRING AND TUBING REFERENCES ON THE PARTS LIST.
G103 0004	ALL PDP-11	F	APR 70 - CHANGES R17 FROM A 100 OHM TRIMPOT TO A 500 OHM TRIMPOT. G103 CIRCUIT SCHEMATIC REVISION C
G616 0001	N.A.	B	APR 70 - DELETES THE MODULE HANDLE FROM THE G616 PARTS LIST AND ADDS IT TO THE MEMORY STACK PARTS LIST. G616 CIRCUIT SCHEMATIC REVISION B
G616 0002	>G616	B	MAY 70 - INTERCHANGES THE POSITIONS OF THE WIRE M1 AND RESISTOR R1. G616 CIRCUIT SCHEMATIC REVISION C
MMII-E 0010	N.A.	P	MAY 70 - ADDS A MODULE CLIP HOLDER PART NUMBER AND ITS DESCRIPTION TO THE PARTS LIST.
MMII-E 0011	>MMII-E	P	MAY 70 - ADDS MMII-E ALIGNMENT PROCEDURE TO THE PRINT SET.
MMII-E 0012	>MMII-E	U	MAY 70 - CHANGES A HOLE SIZE AND ADDS TWO DIMENS FOR THE G616.

LEGEND

FIELD CODE

- F - Field action may be required
- B - Design ECO
- P - Print or Draw List change
- M - Mechanical ECO

SYMBOL

- > - ECO applicable to future production

ECO CHANGES

- Change are added within the brackets (88 110V 111M)
- 88 - Change for future and updated parts only
- 110V - Change for necessary parts only
- 111M - Change for on and later only - installation by DEC
- 8898 - Change are added (88 111M 112M) on the change for ECO replacement by DEC

MASTER DRAWING LIST REVISIONS	
REV	ECO NUMBER
A	MMII-E-0000
B	MMII-E-0003
C	MMII-E-0004
D	MMII-E-0005
E	MMII-E-0006
F	PDP11-0004

WIRE LIST REVISIONS	
REV	ECO NUMBER
A	MMII-E-0002
B	MMII-E-0004

JUN 7 1976 MMII-E PAGE 1

LEGEND

FIELD CODE

- F - Field action may be required
- B - Design ECO
- P - Print or Draw List change
- M - Mechanical ECO

SYMBOL

- > - ECO applicable to future production

ECO CHANGES

- Change are added within the brackets (88 110V 111M)
- 88 - Change for future and updated parts only
- 110V - Change for necessary parts only
- 111M - Change for on and later only - installation by DEC
- 8898 - Change are added (88 111M 112M) on the change for ECO replacement by DEC

MASTER DRAWING LIST REVISIONS	
REV	ECO NUMBER
M	MMII-E-0009
J	MMII-E-0010
K	MMII-E-0011

WIRE LIST REVISIONS	
REV	ECO NUMBER

JUN 7 1976 PAGE 1

DEC O LOG Engineering Change Order Log

ECO SYNOPSIS pages are updated and published continuously in conjunction with the issuance of ENGINEERING CHANGE ORDERS for all DEC products and are available upon subscription from

DIGITAL EQUIPMENT CORPORATION
FIELD SERVICE INFORMATION CENTER
MAYNARD MASSACHUSETTS 01754

digital EQUIPMENT CORPORATION
MAYNARD MASSACHUSETTS

ECO SYNOPSIS FOR LOGIC OR OPTION

MMII-E

PRODUCT LINE	PUBLICATION DATE OF THIS SYNOPSIS PAGE	PAGE REVISION
PDP-11	APRIL 1978	-

ECO NO	LOGIC OR OPTION SERIAL NO S AFFECTED	FIELD CODE	SYNOPSIS
			REFERENCE ECO 0102-00004
1123 00015	ALL 0110 0411-E	P	JUN 78 - CHANGES CIRCUITRY TO PROVIDE +6.0VDC INSTEAD OF +5VDC FOR THE SENSE AMPLIFIERS. ADDS A HEAT SINK TO J4 TO PROVIDE ADDITIONAL HEAT DISSIPATION. BOTH OF THESE CHANGES ARE UNDERSERVED FOR IMMEDIATE REPAIR IN THE FIELD. IT IS TO BE PHASED IN ON THE 0110-E. CHANGES CIRCUITRY TO SPEED UP TURN-OFF TIME FOR THE STACK DISCHARGE CIRCUITS. THIS CHANGE IS TO BE PHASED IN ON BOTH THE 0110 AND 0411-E. THE 0411-E CAN BE REWORKED IN THE FIELD.
0225 00013	ALL 0411-E	F	JUL 78 - REDUCES THE VALUE OF RESISTOR R22 TO 2.2K TO SPEED UP STABILIZATION OF THE 5VDC SUPPLY REFERENCE VOLTAGE. SOLVES THE PROBLEM OF LOSS OF MEMORY DATA DURING POWER UP ON POWER 00000.
0411-E 00012	0411-E	A	JUL 78 - SPECIFIES A REMOVAL OF THE 0411-E MODULES.
0411-E 00010	0411-E 100-0530	F	AUG 78 - DELETES CONFLICTING REFERENCES TO THE IC'S ON THE 0122 FROM THE 0411-E LOGIC PRINTS.
0411-E 00015	0411-E 100-0530	F	SEP 78 - CONNECTS THE SIGNAL BUS "AC LC L" FROM THE PUNCH BUS TO THE 0411-E. CONNECTS THE SIGNAL BUS "AC LU L" FROM THE PUNCH BUS TO THE 0411-E. THESE CHANGES ENSURE PROPER OPERATION OF THE PUNCH FAIL OPTION IN MULTIPLE JOB SYSTEMS. THIS ECO MUST BE INSTALLED IN CONJUNCTION WITH ECOS 0411-00010, 0411-00017, AND 0411-00016 AND IS APPLICABLE TO ALL MULTIPLE JOB SYSTEMS.
0411-E 00010	ALL 0411-E SHIPPED JAN 78 JUL 1978	F	AUG 78 - PRINTS A COPY OF THE DATA SHEET UNDER INSTRUCTIONS FOR CONNECTION. IMPROPERLY WIRED J215 WHICH WAS SHIPPED PREVIOUSLY AND REPAIRS OF 1978. SYMPTOMS OF THIS MEMORY SENSE PROBLEM INCLUDE DATA ERRORS, LOW MEMORY MARGINS, AND NON-INTERCHANGEABILITY OF 0100 MODULES.

ECO NO	LOGIC OR OPTION SERIAL NO S AFFECTED	FIELD CODE	SYNOPSIS
0411-E 00017	0411-E 100-0530	F	JAN 78 - CORRECTS THE TEST PROCEDURE TO SPECIFY CHANGING THE SENSE SENSING FROM 210 NSFC TO 220 NSFC TO IMPROVE MEMORY PERFORMANCE. ECO 0411-E-0225 SUPERSEDES THIS P22 NSFC SENSE SENSING. REVISIONS TO 210 NSFC. SENSING CHANGE WAS TO BE PHASED IN ON IMMEDIATE PERFORMANCE AND A PENDING THE REFERENCE VOLTAGE. CHANGES THE TIME TEST. REVISES THE BLOCK SCHEMATIC TO REFLECT CHANGES MADE TO THE 0411-E CIRCUIT SCHEMATIC. IMPROVED TESTS AND FLOW DIAGRAMS.
0411-E 00018	0411-E	F	JAN 78 - CHANGES SLOTTING OF THE 000 PIN BLADES SO AS TO ELIMINATE THE PROBLEM OF THE 000 PIN BLADES BEING INSERTED AND REMOVED.
0411-E 00019	0411-E	F	MAR 78 - UPDATES DOCUMENTATION TO INCLUDE THE 0411-E MODULE. UPDATES PRINTS TO INCLUDE INSTRUCTIONS FOR INSTALLING MEMORY.
0411-E 00020	0411-E WITH ECO 0411-E-00017	F	MAR 78 - THIS ECO REVISIONS THE SENSE SENSING SPECIFICATION OF ECO 0411-E-00017. CORRECTS THE TEST PROCEDURE TO SPECIFY SENSING THE SENSE AT 210 NSFC. SENSING IS AT 220 NSFC AS SUGGESTED IN ECO 0411-E-00017 IS TOO LATE FOR OPTIMUM PERFORMANCE.

MMII-E-00021 CODE P ML V
MAY 78 PROBLEM Packaging instructions for the PDP-11 memory stack are not included in the print set.
CORRECTION Add packaging instructions to MMII-E drawing add list in plant effectivity. Documentation change only.

MMII-E-00022 CODE D ML W
MAR 78 PROBLEM When some modules when other options are placed along with an MMII-E has failed to operate correctly.
CORRECTION Install a module protection plate.
In plant effectivity: Retire all MMII-E's as required. Time To Install And Test 0 Hour. Kit Contents: Kit Contents.
Kit Prints And Parts

MMII-E-00023 CODE P ML Y
APR 78 CORRECTION Update test procedure.
In plant effectivity: Documentation change only.

MMII-E-00024 CODE F ML AA WL E
MAY 78 PROBLEM 1. Strobe signals and TSM have too much noise on them.
CONNECTION 1. Install twisted pair wiring for these signals.
PROBLEM 2. RAM M signal has too many leads on.
CORRECTION 2. Develop another MMII-E signal to share the lead.
In plant effectivity: Rework immediately.
Field effectivity: Retire all MMII-E.
In revision: 0.3 week. Time To Install And Test 0 Hour. Kit Contents: Kit Prints only.

LEGEND

P = Field Service Order to be returned
D = Design Error
F = Print or Drawing of change
M = Manufacturer Error

SYNOPSIS

> ECO approved by future production

000 Change

Changes are made within the brackets "04 100 1100"
04 = Change for future and updated print only
10 = Change for revision only only
11 = Change for on and off only
1000 = Change for on and off only
1100 = Change for on and off only
1100 = Change for on and off only

MASTER DRAWING LIST REVISIONS

REV	ECO NUMBER	REV	ECO NUMBER
1	0411-E-00013		
2	0411-E-00014		
3	0411-E-00015		
4	0411-E-00016		

WIRE LIST REVISIONS

REV	ECO NUMBER	REV	ECO NUMBER
	0411-E-00015		

JUN 7 1978

LEGEND

P = Field Service Order to be returned
D = Design Error
F = Print or Drawing of change
M = Manufacturer Error

SYNOPSIS

> ECO approved by future production

000 Change

Changes are made within the brackets "04 100 1100"
04 = Change for future and updated print only
10 = Change for revision only only
11 = Change for on and off only
1000 = Change for on and off only
1100 = Change for on and off only

MASTER DRAWING LIST REVISIONS

REV	ECO NUMBER	REV	ECO NUMBER
4	0411-E-00017		
5	0411-E-00018		
6	0411-E-00019		
7	0411-E-00020		

WIRE LIST REVISIONS

REV	ECO NUMBER	REV	ECO NUMBER
	0411-E-00017		

JUN 7 1978

ECO

QUICK

CHECK

MM11-E/F FIELD CODED ECO'S

G102	B2, B3, C4, B6
G103	C2, C4, C5, C7
G225	C3, C7
G226	C4
M729	B2, C3 & A & B
M1091	C1
M7290	C2, C3
MM11-E	C15, C16, C17, C20, D22, B24
MM11 F	D1, C3

MM11-E/F ECO PARTS

<u>NAME</u>	<u>ECO#</u>	<u>QTY</u>	<u>PART NUMBER</u>	<u>COMMENTS & DESCRIPTION</u>
G102	#2	1	19-09849	I.C.
	#3	8	13-03064	Resistor
	#4	4	10-00027	Capacitor
		4	13-09995-0	Resistor
		1	16-09996-0	Indicator
	#6	4	10-00018	Capacitor
G103	#2	3	19-09057	I.C.
	#4	1	13-05631	Resistor
	#5	2	13-02602	Resistor
		2	13-09994-0	Resistor
		1	13-00295	Resistor
		2	10-00027	Capacitor
		1	11-09991	Diode
		1	11-09990	Diode
		1	16-09996-0	Conductor
		1	12-10001-0	Heat sink
	#7	1	10-10274	Capacitor
G225	#3	1	13-00417	Resistor
	#7	4	90-08493	Washers
A/R			90-08268	Thermal compound
G226	#4	1	10-10274	Capacitor
M792	#3	1	19-05547	I.C.
M1091	#1	1	M1091 etch "B"	if applicable module
MM11-F	#1	1	74-08490	Memory shield
MM11-E	#2	1	74-08490	Memory shield

MM11-E/F PARTS BREAKDOWN

7006405	- Logic Frame
7006468	- MM11-E Wired assembly
70007263	- MM11-F Wired assembly
G102	- Sense Inhibit Card
G103	- Memory Levels & Gates
G225	- X-Y Current Generator
G226	- X-Y Current Generator
H207	- 4K 16 Bit Core Memory Stack
M109	- Device Select
M729	- MM11-E Control Logic
M1091	- Device Select
M7290	- Control Logic & Timing
MM11-E	- 4K Single Memory Unit
MM11-EX	- 4K Interleaved
MM11-F	- 4K Single Memory Unit
MM11 FP	- Single Parity Memory Unit
MM11 FX	- Interleaved Memory (jumpers)

MM11-E/F FIELD CODED ECO's

G102	B2, B3, C4, B6
G103	C2, C4, C5, C7
G225	C3, C7
G226	C4
M729	B2, C3 & A & B
M1091	C1
M7290	C2, C3
MM11-E	C15, C16, C17, C20, D22, B24
MM11-F	D1, C3

MM11 E/F ECO PARTS

<u>NAME</u>	<u>ECO#</u>	<u>QTY</u>	<u>PART NUMBER</u>	<u>COMMENTS & DESCRIPTION</u>
G102	#2	1	19-09849	I.C.
	#3	8	13-03064	Resistor
	#4	4	10-00027	Capacitor
		4	13-09995-0	Resistor
		1	16-09996 0	Indicator
	#6	4	10-00018	Capacitor
G103	#2	3	19-09057	I.C.
	#4	1	13-05631	Resistor
	#5	2	13-02602	Resistor
		2	13-09994 0	Resistor
		1	13-00295	Resistor
		2	10-00027	Capacitor
		1	11-09991	Diode
		1	11-09990	Diode
		1	16-09996-0	Conductor
		1	12-10001-0	Heat sink
	#7	1	10-10274	Capacitor
G225	#3	1	13-00417	Resistor
	#7	4	90-08493	Washers
		A/R	90-08268	Thermal compound
G226	#4	1	10-10274	Capacitor
M792	#3	1	19-05547	I.C.
M1091	#1	1	M1091 etch "B"	if applicable module
MM11-F	#1	1	74-08490	Memory shield
MM11-E	#2	1	74-08490	Memory shield

REVISION DATE APRIL 1970

M11-E MEMORY		ETCH	OPTION	OPTION SERIAL #	PDP	SYSTEM SERIAL #	LOCATION	CAB	BOX	SYS. UNIT	SLOT	IPB	PAGE 1 OF
ECO	RELEASE DATE	CS	ETCH WL	ECO HRS. TIME	QUICK CHECK CAUTION - NOT COMPLETE ECO		QTY	PARTS REQUIRED	MAINDECS REQUIRED	PRINT SET UPDATE	ACTUAL INSTALL TIME	DATE INSTALLED	
00002	01/70		A		Jumper D01-B1 to E01-E1			NIL					
00003	01/70				Black wire of twisted pair from C02-C2 to E03-C2			NIL					
00006	02/70		B		Jumper A01-S2 to A04-S2			NIL					
C 00015	09/70		C		<u>NOTE:</u> 1) Rework multiple box systems only 2) Must have ECO 5408475-00006 and M930-00001 Jumper A03-S2 to B04-F2			NIL					
C 00016	12/70			1.5	Blue jumper from E01-C1 to E01-E2 looping through logic			NIL					
C 00017	01/71		D		Jumper B04-F1 to A03-R2			NIL					
C 00020	03/71				<u>NOTE:</u> F/S information regarding strobe and threshold level settings			NIL					
D 00022	04/71			1.0	A module protection plate along M11-E memory bank		1	74-08490					
B 00024	06/72		E	1.0	<u>NOTE:</u> Must have ECO M729 #3 Black wire of twisted pair from E01-C2 to F01-C2.			NIL					

M11-E		MEMORY		ETCH	OPTION	OPTION SERIAL#	PDP	SYSTEM SERIAL	LOCATION	CAB	BOX	SYS. UNIT	SLOT	IPB	PAGE 2 OF
ECO	RELEASE DATE	CS	ETCH WL	ECO HRS. TIME	QUICK CHECK CAUTION - NOT COMPLETE ECO			QTY	PARTS REQUIRED	MAINDECS REQUIRED	PRINT SET UPDATE	ACTUAL INSTALL TIME	DATE INSTALLED		
00025	05/76				NOTE: Documentation change				NIL						

MM11-F 4K 16 BIT MEMORY			ETCH	OPTION	OPTION SERIAL #	PDP	SYSTEM SERIAL #	LOCATION	CAB	BOX	SYS. UNIT	SLOT	IPB	PAGE 1 OF
ECO	RELEASE DATE	CS	ETCH #	ECO HRS. TIME	QUICK CHECK CAUTION - NOT COMPLETE ECO	QTY	PARTS REQUIRED	MAINDECS REQUIRED	PRINT SET UPDATED	ACTUAL INSTALL TIME	DATE INSTALLED	CD NO.		
D 00001	3/72			1.0	A module protection plate along each MM11-F bank.	1	74-08490							
00002	5/72				<u>NOTE:</u> Print update of test procedure		Nil							
C 00003	8/72		A	1.0	<u>NOTE:</u> Must have ECO M7290-C0003 Red jumper C01-C2 to E01-T1		Nil							

.02 SENSE INHIBIT CARD				ETCH	OPTION	OPTION SERIAL #	PDP	SYSTEM SERIAL #	LOCATION	CAB	BOX	SYS. UNIT	SLOT	IPB	PAGE 1 OF 1
ECO	RELEASE DATE	CS	ETCH /L	ECO HRS. TIME	QUICK CHECK CAUTION - NOT COMPLETE ECO			QTY	PARTS REQUIRED	MAINDECS REQUIRED	PRINT SET UPDATED	ACTUAL INSTALL TIME	DATE INSTALLED	CD NAME	
00001	3/70		C		NOTE: Documentation change				Nil						
00002	3/70	B	D		E5 is a DEC I.C. <u>74H01-1</u> E5 is the 1st I.C. from AS1			1	19-09849						
00003	4/70	B	D		NOTE: Supplement to ECO # 2 R4 is a <u>75</u> ohm 1/8W resistor R4 is the 1st resistor from AA1			8	13-03064						
00004	6/70	C	D	.5	R2 is a <u>56</u> ohm 1/2W 5% resistor R2 is the 1st resistor above E2 E2 is a DEC transformer			4 4 1	10-00027 13-09995-0 16-09996-0						
00005	6/71		D		NOTE: See ECO # B6				Nil						
00006	4/71	D	D	.25	C3 is a <u>120</u> MMF 5% capacitor C3 is the closest capacitor from AA1			4	10-00018						

G103 MEMORY LEVELS & GATES				ETCH	OPTION	OPTION SERIAL #	PDP	SYSTEM SERIAL #	LOCATION	CAB	BOX	SYS. UNIT	SLOT	IPB	PAGE 1 OF 1
ECO	RELEASE DATE	CS	ETCH WL	ECO HRS. TIME	QUICK CHECK CAUTION - NOT COMPLETE ECO			QTY	PARTS REQUIRED	MAINDECS REQUIRED	PRINT SET UPDATED	ACTUAL INSTALL TIME	DATE INSTALLED	CE NA	
00001	1/70	A	A		<u>NOTE:</u> Print update				N/A						
C 00002	3/70	B	A	.5	E2 is a I.C. DEC 74H10 E2 is the 1st i.c. from AH1			3	19-09057						
00003	3/70		A		<u>NOTE:</u> Print update				Nil						
C 00004	4/70	C	A	.25	R17 is a 500 ohm trim pot R17 is located in bottom left corner			1	13-05631						
C 00005	6/70	D	A	1.0	R1, R2 are <u>56</u> ohm, $\frac{1}{4}$ W, 5% resistors R1 & R2 are the two resistors just right of R4 R4 is the 10W resistor nearest the top right corner			2 2 1 2 1 1 1 1	13-02602 13-09994-0 13-00295 10-00027 11-09991 11-09990 16-09996-0 12-100001-0						
00006	2/71	E	A		<u>NOTE:</u> Print change				Nil						
C 00007	1/72	F	A	.25	C11 is a <u>.22</u> mfd 50V capacitor C11 is the only capacitor left of the two transistors at AC1			1	10-10274						

G225 X - Y CURRENT GENERATOR				ETCH	OPTION	OPTION SERIAL #	PDP	SYSTEM SERIAL #	LOCATION	CAB	BOX	SYS. UNIT	SLOT	IPB	PAGE 1 OF
ECO	RELEASE DATE	CS	ETCH .L	ECO HRS. TIME	QUICK CHECK CAUTION - NOT COMPLETE ECO			QTY	PARTS REQUIRED	MAINDECS REQUIRED	PRINT SET UPDATED	ACTUAL INSTALL TIME	DATE INSTALLED	CE	
C 00003	7/70	B	B	1.0	R22 is a 2.2K 1/4W 5% resistor R22 is the 3rd resistor from bottom left corner			1	13-00417						
00004	7/70	C	C		R5 is a 680 ohm 1/4W 5% resistor R5 is the 1st resistor from AA1			4	12-02313						
								4	13-00347						
								4	13-00394						
00005	8/70	C			<u>NOTE:</u> Print change				N11						
00006	9/70	D	D		<u>NOTE:</u> New etch rev				N11						
C 00007	5/71	E	D	1.0	<u>NOTE:</u> Rework only "D" etch boards Insulating washers on all four heat sinks are tight and can not be rotated.			4	90-08493 90-08268 (thermal compound)						

G226 X - Y DECODER SWITCH				ETCH	OPTION	OPTION SERIAL #	PDP	SYSTEM SERIAL #	LOCATION	CAB	BOX	SYS. UNIT	SLOT	IPB	PAGE 1 OF
ECO	RELEASE DATE	CS	ETCH WL	ECO HRS. TIME	QUICK CHECK CAUTION - NOT COMPLETE ECO			QTY	PARTS REQUIRED	MAINDECS REQUIRED	PRINT SET UPDATED	ACTUAL INSTALL TIME	DATE INSTALLED		
00001	11/69	A	C		C22 is a .1ufd 50V capacitor C22 is below the two 1/2W resistors on board which are separated by a capacitor				N/A						
00002	3/70	B	C		NOTE: Documentation				Nil						
00003	3/70	C	C		Resistor closest to the bottom left corner is a 120 ohm 1/2W 5% resistor				N/A						
C 00004	11/71	D	D		C22 is a .22 ufd 50V capacitor C22 is below the two 1/2W resistors on board which are separated by a capacitor			1	10-10274						

M729 MM11-E Control Logic				ETCH	OPTION	OPTION SERIAL #	PDP	SYSTEM SERIAL #	LOCATION	CAB	BOX	SYS. UNIT	SLOT	IPB	PAGE 1 OF 1
ECO	RELEASE DATE	CS	ETCH WL	ECO HRS. TIME	QUICK CHECK CAUTION - NOT COMPLETE ECO			QTY	PARTS REQUIRED	MAINDECS REQUIRED	PRINT SET UPDATE	ACTUAL INSTALL TIME	DATE INSTALLED	CE NA	
00001	03/70	A	B		NOTE: 1) New etch rev 2) Rework Etch "A" Revs E5 is aDEC I.C. 74 H 74				N/A						
B 00002	01/71	B	C	1.0	NOTE: 1) Must be installed in interleaved memories and optional for non-interleaved memory 2) Rework etch "B" rev only (ECO #3 has better rework instructions) No capacitor between the 270 OHM and 390 OHM resistors located near the upper left hand corner				NIL						
C 00003 &A &B	06/72 01/73	C	C	1.5	NOTE: ECO# 3 contains ECO #2 & #3 rework instructions for all etch revs Measure an open CKT from E04-09 to E09-01 E09 is the 4th I.C. from AK1			1	19-05547	DZQGQ DZQCA DZQKB					

M1091 DEVICE SELECT				ETCH	OPTION	OPTION SERIAL #	PDP	SYSTEM SERIAL #	LOCATION	CAB	BOX	SYS. UNIT	SLOT	IPB	PAGE
															1 OF
ECO	RELEASE DATE	CS	ETCH NL	ECO HRS. TIME	QUICK CHECK CAUTION - NOT COMPLETE ECO			QTY	PARTS REQUIRED	MAINDECS REQUIRED	PRINT SET UPDATED	ACTUAL INSTALL TIME	DATE INSTALLED		
C 00001	3/71	*	A	N/A	NOTE: MM11-E systems M1091 module if 16K of memory or more			1	M1091 etch "B" (if applicable)						
00002	3/71	A	B		NOTE: MM11-E, MM11-F and MMR11-E memory systems phase in M1091 modules. Check for M1091 module			1	M1091 Etch "B"						

REVISION DATE

M7290 CONTROL AND LOGIC				ETCH	OPTION	OPTION SERIAL #	PDP	SYSTEM SERIAL #	LOCATION	CAB	BOX	SYS. UNIT	SLOT	IPB	PAGE 1 OF
ECO	RELEASE DATE	CS	ETCH WL	ECO HRS. TIME	QUICK CHECK CAUTION - NOT COMPLETE ECO			QTY	PARTS REQUIRED	MAINDECS REQUIRED	PRINT SET UPDATED	ACTUAL INSTALL TIME	DATE INSTALLED	C	
00001	2/71	C	D		Jumper E06-06 to E31-10 feed through E6 is the 3rd I.C. from AL1 E31 is the last I.C. on board				Nil						
C 00002	9/71	D	E D C	2.0	NOTE: Rework "C" & "D" etch boards Jumper E03-03 to T07-10 feed through				Nil						
C 00003	8/72	E	F E D C	4.0	NOTE: 1) Must have ECO MM11-F-C0003 2) Rework all previous etch boards Jumper E02-08 to AC1				Nil	DZMMA thru DZMMI					

FECO'S

EQUIPMENT CORPORATION
ENGINEERING
CHANGE ORDER

REC'D. BY INPR. SER. **B 10 70**
 SPECS RELEASE **9 12 70**

TYPE OF CHANGE
 ELECTRICAL
 MECHANICAL
 MODULES

CHANGE NO. **M11E-00015**
 DOCUMENTATION PROJECT NUMBER
 ACT. PROD. LINE TYPE OR DISCRETE NO. **1 1 0 7 4 2 8**
 MANUFACTURING PROJECT NUMBER
 ACT. PROD. LINE TYPE OR DISCRETE NO.

UNIT NAME MEMORY MODEL NO. M11E

PREWIRED OPTIONS AFFECTED

MODEL NO.	VARIATION

CHANGE TESTED IN SERIAL NO. _____ BY _____

ESTIMATED TIME TO INSTALL 4 MINUTES

PARTS ADDED OR DELETED IF YES REFER TO SEPARATE SHEET
 SHOP MODEL AFFECTED
 SYSTEMS PROGRAMS AFFECTED
 DIAGNOSTIC PROGRAMS AFFECTED
 TECHNICAL PUBLICATIONS AFFECTED

YES	NO
<input type="checkbox"/>	<input checked="" type="checkbox"/>
<input type="checkbox"/>	<input checked="" type="checkbox"/>
<input type="checkbox"/>	<input checked="" type="checkbox"/>
<input type="checkbox"/>	<input checked="" type="checkbox"/>
<input type="checkbox"/>	<input checked="" type="checkbox"/>

BREAK-IN POINT (DATE/SERIAL NO.)
 FIELD RETROFIT ON MULTIPLE BOX SYS. ONLY.
 PHASE-IN PRODUCTION-- ALL MULTIPLE BOX SYS. FOR THE MONTH OF AUG. ALL MACHINES AS OF AUGUST 24, 1970.
 SER. #100 ← 953 →

PROBLEM:

- TO ALLOW PROPER POWER FAIL OF MULTIPLE BOX SYSTEMS.
- SIGNAL BUS AC LO L MUST BE CONNECTED FROM THE POWER BUS TO THE UNIBUS.
 - SIGNAL BUS DC LO L MUST BE CONNECTED FROM THE POWER BUS TO THE UNIBUS.
 - THIS ECO REQUIRES BOTH OF THE FOLLOWING: ECO #5408475-00006; ECO #M930-00001.

ALL REFERENCED CHANGES MUST BE MADE SIMULTANEOUSLY IN A GIVEN SYSTEM.

CORRECTION:

- INSTALL WIRES.
- CORRECT PRINTS.
- NOTE: IF INSTALLATION OF THIS UNIT CREATES A MULTIPLE BOX SYSTEM, THIS ECO AND ECO NUMBER 5408475-00006; ECO NUMBER M930-00001 MUST BE INSTALLED. ONE SET OF CONNECTIONS BETWEEN THE POWER BUS AND UNIBUS ARE REQUIRED FOR EACH BALL WITHIN A SYSTEM.

DRAWINGS AFFECTED

NUMBER	D.L. REV.	D.W. REV.
A-M1-M11-E	N	P
X-M1-M11-E-07	B	C
D-IC-M11-E-09	D	A

FIELD SERVICE CODE

F

ORIGINATOR Richard V. Manion DATE 8-3-70
 PRODUCTION ENG. D. Call DATE 8-3-70
 DESIGN ENG. Peter Durant DATE 8-2-70
 OTHER R. J. Farrier AGK DATE 8-3-70

PRODUCT LINES AFFECTED
PDP-11

DWG LOC.
B-6

B-4

M920
B01 M920
B04

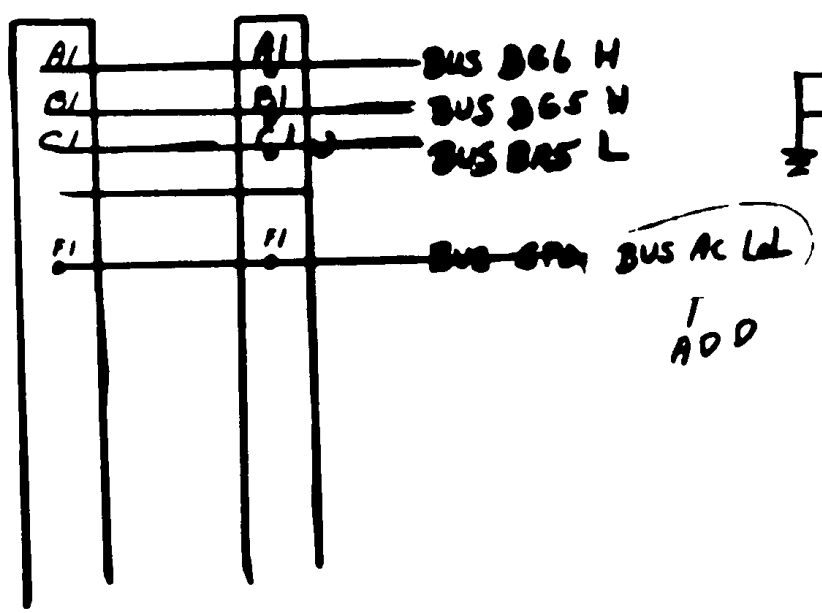

M920
B01 M920
B04

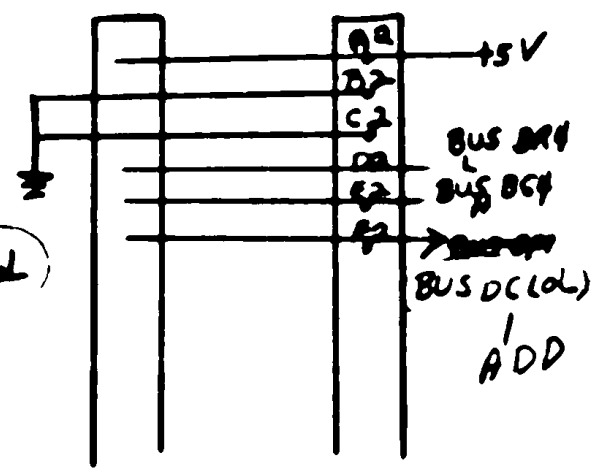

ECO # MM11E-00015

D-IC-MM11-E-09

NEW
REV.
A

DWG NO	REV LET	NO OF SHEETS	TITLE
D-IC-MM11-E-09	A	1	I/O CONNECTORS
K-WL-M11-E-07	BC	2	WIRE LIST

ECO # MM11E-00015

A-ML-MM11E

NEW
REV
P

ADD/DELETE SHEET

MAKE ALL DELETIONS FIRST

PAGE _____ OF _____

COLOR	SIGNAL NAME	FROM PIN	TO PIN	COMPONENTS	ADD	DEL
	BUS FLOOR	BØ+F1	AØ+1		X	
	BUS DCLOL	BØ+F2	AØ+3		X	

ECO NUMBER MM11E-00015

MADE BY *[Signature]*

DRAWING NUMBER AFFECTED			
CODE	SIZE	NUMBER	NEW REV LTR
11L	15	MM11-E-07	C

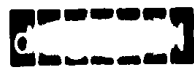

EQUIPMENT CORPORATION

ENGINEERING CHANGE ORDER

REC'D BY INFO SER
SPECO RELEASE

MO	DAY	YR
8	6	70
8	22	7

TYPE OF CHANGE

ELECTRICAL	<input checked="" type="checkbox"/>
MECHANICAL	<input type="checkbox"/>
MODULES	<input type="checkbox"/>

CHANGE NO. MM11E-00016

DOCUMENTATION PROJECT NUMBER

ACT	PROD	LINE	TYPE OR DISCRETE NO				
	1	1	0	7	4	2	8

MANUFACTURING PROJECT NUMBER

ACT	PROD	LINE	TYPE OR DISCRETE NO				

UNIT NAME PDP-11 MEMORY

MODEL NO. MM11E

PREWIRED OPTIONS AFFECTED

MODEL NO.	VARIATION

CHANGE TESTED IN SERIAL NO _____ BY _____

ESTIMATED TIME TO INSTALL _____

- PARTS ADDED OR DELETED (IF YES REFER TO SEPARATE SHEET)

YES	NO
<input type="checkbox"/>	<input checked="" type="checkbox"/>
- SHOP MODEL AFFECTED

<input type="checkbox"/>	<input checked="" type="checkbox"/>
--------------------------	-------------------------------------
- SYSTEMS PROGRAMS AFFECTED

<input type="checkbox"/>	<input checked="" type="checkbox"/>
--------------------------	-------------------------------------
- DIAGNOSTIC PROGRAMS AFFECTED

<input type="checkbox"/>	<input checked="" type="checkbox"/>
--------------------------	-------------------------------------
- TECHNICAL PUBLICATIONS AFFECTED

<input type="checkbox"/>	<input checked="" type="checkbox"/>
--------------------------	-------------------------------------

BREAK-IN POINT (DATE/SERIAL NOS)

SER. #100 THRU 953 AND ALL FUTURE.
ALL IN PROCESS.

PROBLEM:

- TIMING + FLOW DIAGRAM WPONG.
- NOT ENOUGH INFORMATION GIVEN ON THE DRAWING TO INSURE THE REQUIRED RESULTS WHEN HAND WIRE. WRAPPING. TWISTED PAIRS WILL PICK BACK PLANE NOISE UNLESS DONE CORRECTLY.

CORRECTION:

- CORRECT TIMING + FLOW DIAGRAM
- ADDITIONAL INFORMATION PUT ON THE PRINT.

DRAWINGS AFFECTED

NUMBER	OLD REV.	NEW REV.
A-ML-MM11-E	M	N
D-TD-MM11-E-08	A	B
D-AD-7006468-0-0	B	C
A-PL-7006468-0-0	B	C

FIELD SERVICE CODED

D

ORIGINATOR Richard V. Manion x-2814 DATE 8-2-70

PRODUCTION ENG. D. Call DATE 8-3-70

DESIGN ENG. Peter Durant DATE 8-3-70

OTHER R. J. FARRIER AGK DATE 8-4-70

PRODUCT LINES AFFECTED

PDP-11

DWG LOC.
D-4

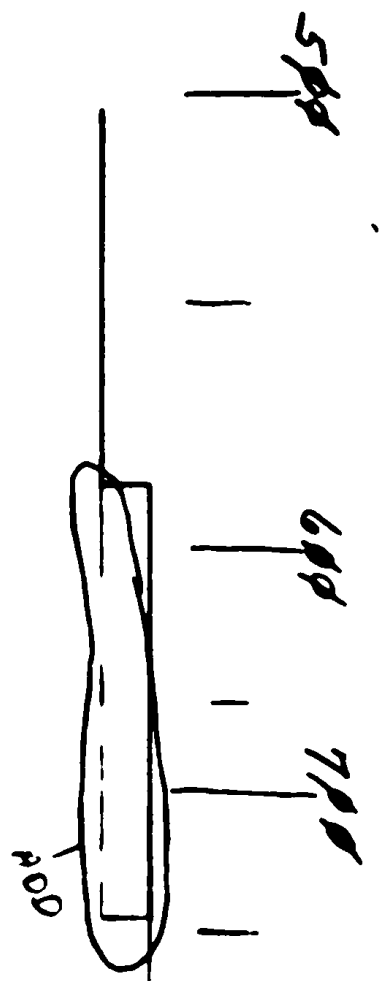

CHECK RAKE E-BUD

NEW REV
D

C 4+3

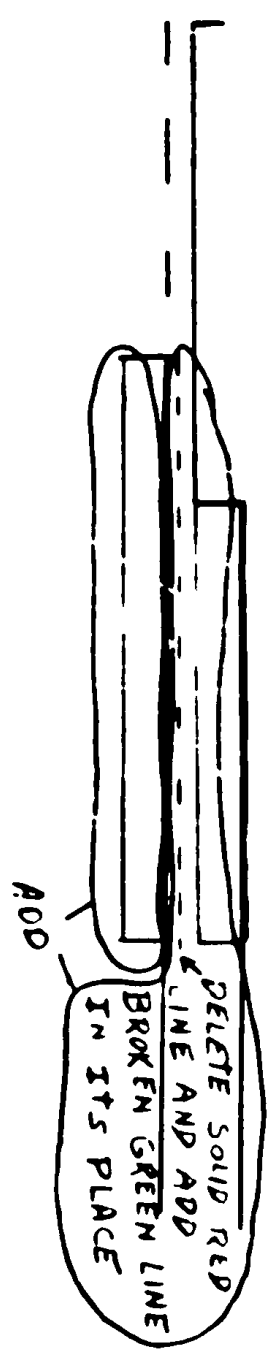

B-5



B5+6

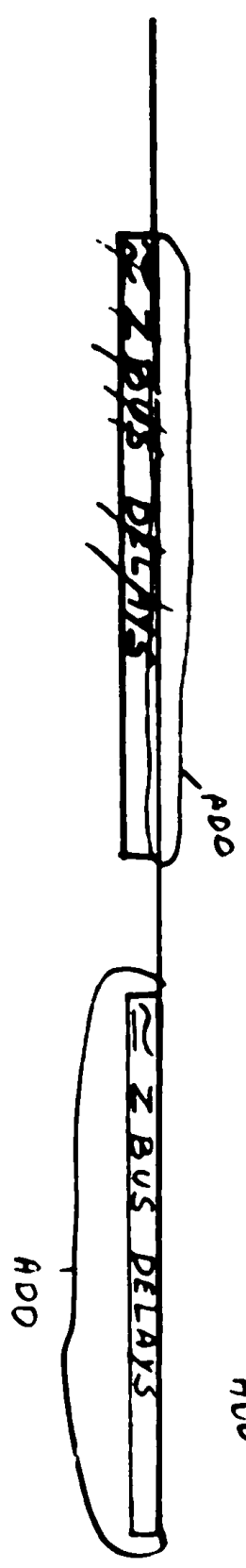

ECO # MM11E-00016

D-TD-MM11E-08

1
3
3

LENGTH SHOULD BE A MAXIMUM OF
 $2\frac{1}{4}$ INCHES. CHECK DRAWING FOR
 LENGTH AND FOR HOW LOOPS SHOULD
 BE DRESSED INTO LOGIC.

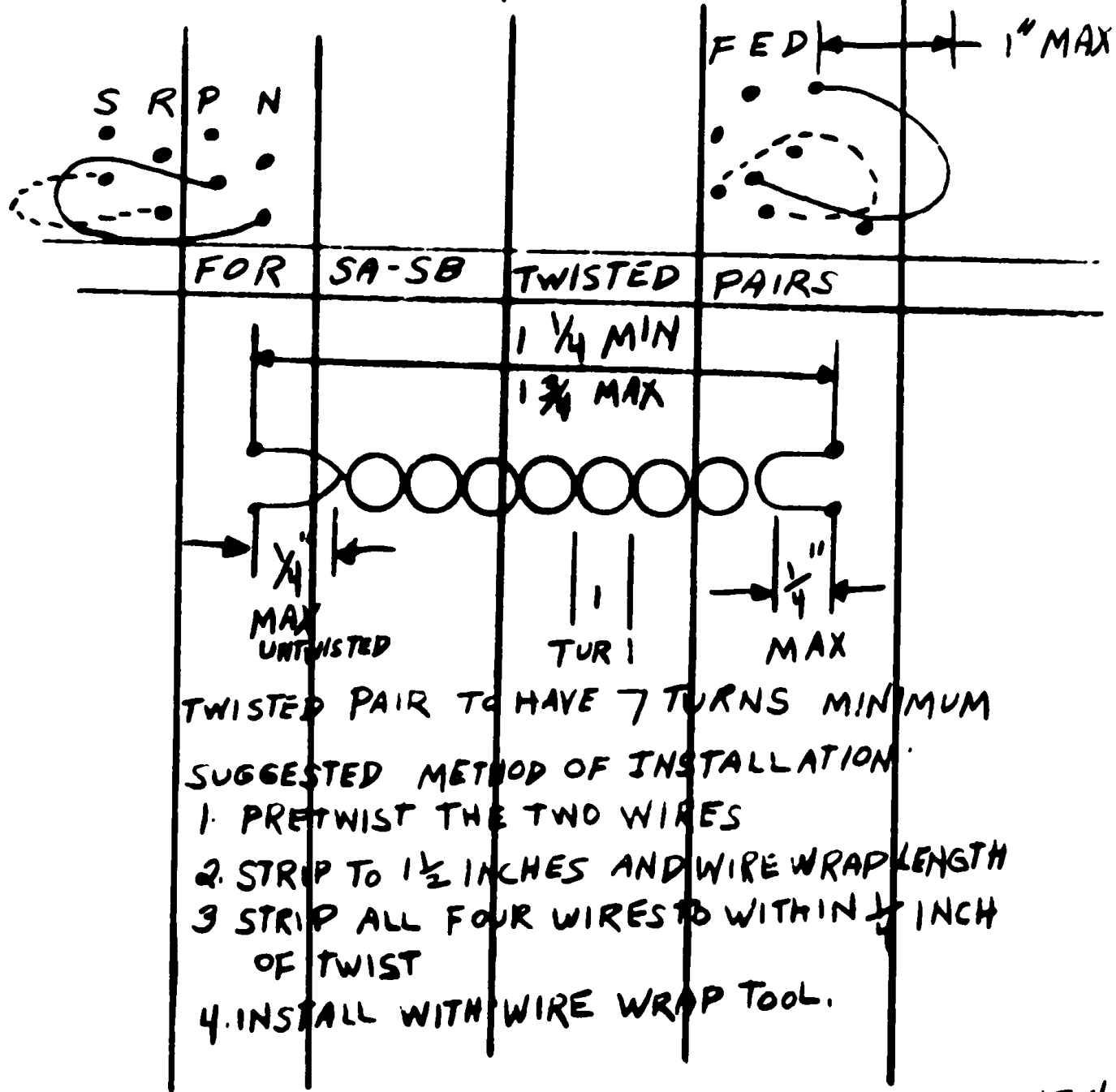

ECO# MM11E-00016 D-AD-7006468-0-0

NEW
 REV
 C

DWG NO.	REV LET
D-AD-7006468-0-0	BC
A-PL-7006468-0-0	BC
D-TD-MM11E-08	AB

ECO# MM11E-00016

A-ML-MM11E

NEW
REV.
N

ENGINEERING CHANGE ORDER

ECO NO. MM11E-00017
Sheet 1 of 4

ORIGINATOR: RICHARD MANION
 RECEIVED CHG. DATE: 12/22/70
 ISSUED ECO DATE: 1-22-71
 FINAL RELEASE DATE: _____
 DISCRETE PROJECT NUMBER: 11 07602

EQUIPMENT AFFECTED

TYPE CHANGE	UNIT TO BE CHANGED	CHECKLIST	YES	NO
ELECTRICAL <input checked="" type="checkbox"/>	MM11-E	SHOP MODEL	<input type="checkbox"/>	<input checked="" type="checkbox"/>
MECHANICAL <input type="checkbox"/>	PRODUCT LINES	SYSTEMS PROGRAMS	<input type="checkbox"/>	<input checked="" type="checkbox"/>
MODULE <input type="checkbox"/>		DIAGNOSTICS	<input type="checkbox"/>	<input checked="" type="checkbox"/>
SUBASSEMBLY <input type="checkbox"/>	PDP11	TECHNICAL PUB	<input checked="" type="checkbox"/>	<input type="checkbox"/>
MFG/FIELD PROCEDURE <input type="checkbox"/>		TEST PROGRAMS	<input type="checkbox"/>	<input checked="" type="checkbox"/>
TEST INFORMATION		TESTER	<input type="checkbox"/>	<input checked="" type="checkbox"/>
SERIAL #		MFG FIELD PROCEDURE	<input type="checkbox"/>	<input checked="" type="checkbox"/>
BY		PACKAGING INSTRUCTIONS	<input type="checkbox"/>	<input checked="" type="checkbox"/>
		TOOLING	<input type="checkbox"/>	<input checked="" type="checkbox"/>

BREAK IN POINT				SIGNIFICANCE	
SYSTEM	MODULE/OPTION	FIELD	REWORK	CODE	
	MM11-E	DISTRIBUTED FOR FIELD SERVICE INFORMATI.O ONLY		05	REQ TO MEET SPECIFICATION <input type="checkbox"/>
					PROD IMPROVEMENT <input checked="" type="checkbox"/>
					CUSTOMER/FIELD REQ. <input type="checkbox"/>
					FACILITATE MFG <input type="checkbox"/>
					DRAWING CORRECTION <input checked="" type="checkbox"/>
					VENDOR <input type="checkbox"/>

PROBLEM

1. WANTED TO IMPROVE MEMORY PERFORMANCE. STROBE 210 NS WAS TOO EARLY FOR OPTIMUM PERFORMANCE. SOME TIMES CURRENT WAS TOO HIGH FOR OPTIMUM PERFORMANCE WHEN ADJUSTING THE REFERENCE VOLTAGE
2. WIRE LIST WAS NOT CHANGED ACCORDING TO ECO # MM11E-00015.
3. BLOCK SCHEMATIC DOES NOT REFLECT CHANGES OF M729 CIRCUIT SCHEMATIC
4. TIMING AND FLOW DIAGRAM NEEDS TO BE UPDATED.
5. WRITING IN MARGIN

CORRECTION

1. CHANGED TEST PROCEDURE TO IMPROVE MEMORY PERFORMANCE.
2. CORRECT WIRE LIST ACCORDING TO SUBMITTED ADD/DELETE SHEET.
3. UPDATE BLOCK SCHEMATIC PER ATTACHED MARKED UP PRINT.
4. UPDATE TIMING AND FLOW DIAGRAM AS INDICATED.
5. REMOVE WRITING FROM MARGIN.

APPROVAL

DESIGN ENGINEER P. DURANT ENG MGR _____
 PRODUCTION ENGINEER S. CALL FIELD SERVICE _____
 CHIEF ENGINEER _____ (ADVISORY) J. BUZYNSKI

**ENGINEERING CHANGE ORDER
DOCUMENT & MATERIAL
CHANGE**

ECO NO
MM11E-00017
Sheet 2 of 4

ITEM	DOCUMENT/OR PART NUMBER	OLD REV	NEW REV	(PART NAME) DESCRIPTION OF CHANGE	DISP CODE
1	A-ML-MM11-E	P	R	(MASTER LIST) UPDATE REVISION LEVEL ON THE FOLLOWING DRAWINGS: D-BS-MM11-E-05 FROM A TO B K-WL-MM11-E 07 FROM C TO D D-TD-MM11-E-08 FROM B TO C A-SP-MM11-E-11 FROM O TO A	06
2	D-BS-MM11-E-05	A	B	(BLOCK SCHEMATIC) SEE MARKED PRINT THIS ECO.	06
3	K-WL-MM11 E-07	C	D	(WIRE LIST) SEE ADD/DELETE SHEET THIS ECO.	06
4	D-TD-MM11-E-08	B	C	(TIMING DIAGRAM) DELETE CHECK RACE COND. IN MARGIN. INCREASE TIME AND FLOW IN DISZ BEFORE 650NS. INCREASE TIME AND FLOW IN CINZ BEFORE 350 NS.	06
5	A-SP-MM11-E-11	-	A	(ENGINEERING SPECIFICATION) DELETE FROM PARA. 11.0 210 NS . ADD 220NS. ADD TO PARA. 13.4- IF THE MARGIN IS GREATER THAN 1.0V SET VXY AT 0.5 BELOW THE FAILING HIGH END POINT (EXAMPLE IF MARGINS ARE 0.4 TO 1.8V, SET AT 1.3V= 1.8-0.5)	06

DISPOSITION CODES

Use up Present Stock	01	Retrofit to Break in	05
Use Present Stock until New Stock Available	02	Documentation Change Only	06
Rework all Material	03	New Item Purchase	07
Rework until New Stock Available	04	New Item in Stock	08
		New Item on Order	09
		Retain	00

DRA 112A

SEE REVERSE SIDE FOR INSTRUCTIONS

CE
NAM



ENGINEERING CHANGE ORDER
ADD/DELETE SHEET

ECO NO
MIMI-E 00017
Sheet *3* of *4*

WIRE LIST NO. *MIMI-E 07*

TITLE

MAKE ALL DELETIONS FIRST WHEN INSTALLING

SIGNAL NAME	FROM PIN	TO PIN	COMPONENTS	ADD	DEL
<i>BUS AL 20 E</i>	<i>B04F1</i>	<i>A03R2</i>		<i>X</i>	
<i>BUS US 20 E</i>	<i>B04F2</i>	<i>H03S2</i>		<i>Y</i>	

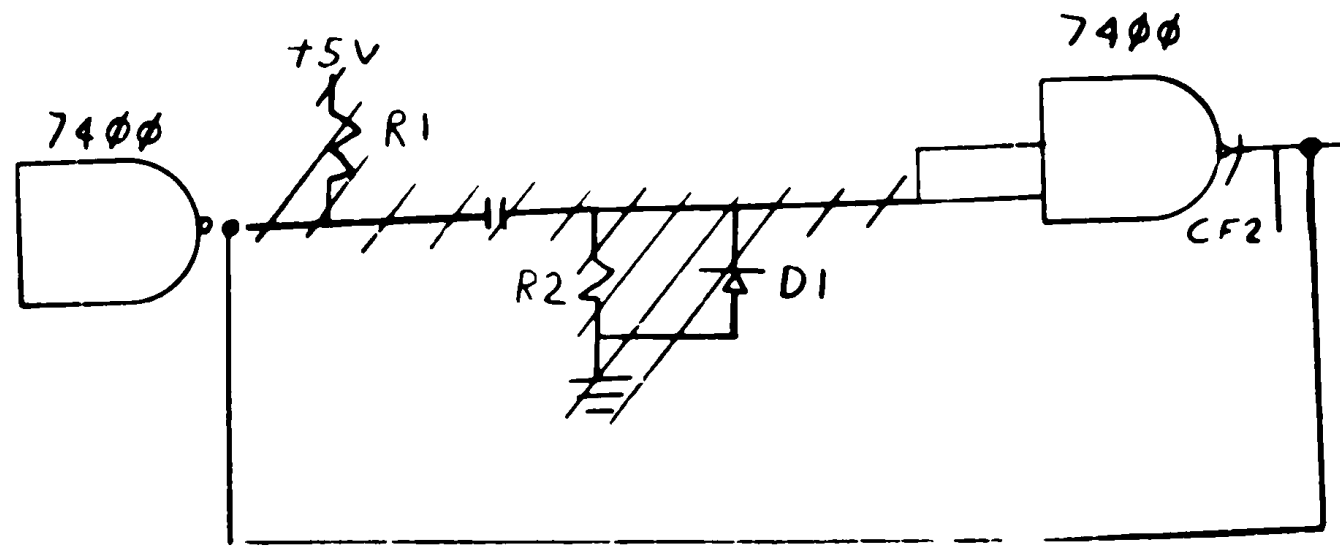

ECO* MM11E-00017

0-BS-MM11-E-05

NEW
REVB

		ENGINEERING CHANGE ORDER		ECO NO MM11E-00020
W.O. 362E CS DM		Sheet 1 of 3		
ORIGINATOR RICHARD MANION	RECEIVED CHG. DATE 3/24/71	ISSUED ECO DATE 3-26 71	FINAL RELEASE DATE 4-13-71	DISCRETE PROJECT NUMBER 11 07602
DATE 3/9/71	EXT 2005			

EQUIPMENT AFFECTED

TYPE CHANGE	UNIT TO BE CHANGED	CHECKLIST	YES	NO
ELECTRICAL <input checked="" type="checkbox"/>	MM11E	SHOP MODEL	<input type="checkbox"/>	<input checked="" type="checkbox"/>
MECHANICAL <input type="checkbox"/>	PRODUCT LINES	SYSTEMS PROGRAMS	<input type="checkbox"/>	<input checked="" type="checkbox"/>
MODULE <input type="checkbox"/>		DIAGNOSTICS	<input type="checkbox"/>	<input checked="" type="checkbox"/>
SUBASSEMBLY <input type="checkbox"/>	PDP11	TECHNICAL PUB	<input checked="" type="checkbox"/>	<input type="checkbox"/>
MFG/FIELD PROCEDURE <input type="checkbox"/>		TEST PROGRAMS	<input type="checkbox"/>	<input checked="" type="checkbox"/>
TEST INFORMATION		TESTER	<input type="checkbox"/>	<input checked="" type="checkbox"/>
SERIAL #		MFG/FIELD PROCEDURE	<input checked="" type="checkbox"/>	<input type="checkbox"/>
BY		PACKAGING INSTRUCTIONS	<input type="checkbox"/>	<input checked="" type="checkbox"/>
		TOOLING	<input type="checkbox"/>	<input checked="" type="checkbox"/>

BREAK IN POINT				SIGNIFICANCE	
SYSTEM	MODULE/OPTION	FIELD	RETROFIT	REWORK	CODE
FILE SERVICE	MM11E	DISTRIBUTED FOR FIELD SERVICE INFORMATION ONLY			06
				REQ TO MEET SPECIFICATION	<input type="checkbox"/>
				PROD IMPROVEMENT	<input checked="" type="checkbox"/>
				CUSTOMER/FIELD REQ	<input type="checkbox"/>
				FACILITATE MFG	<input type="checkbox"/>
				DRAWING CORRECTION	<input checked="" type="checkbox"/>
				VENDOR	<input type="checkbox"/>

PROBLEM

- 1) WANTED TO IMPROVE MEMORY PERFORMANCE. STROBE AT 220 NS AS SUGGESTED IN ECO MM11E-00017 WAS TOO LATE FOR OPTIMUM PERFORMANCE
- 2) PAR 12.0 MM11E TEST PROCEDURE INCORRECT. V THRESHOLD SET TO -5.3V IS TOO LOW.

CORRECTION

- 1) CHANGE STROBE SETTING AS STATED IN PARAGRAPH 11.0 FROM 220 NS TO 210 NS
- 2) CHANGE TEST PROCEDURE . SET V THRESHOLD AT -5.2V

NOTE: REF. ECO MM11E-00017 PROBLEM 1. IF THE CORRECTION FOR PROBLEM (1) IN ECO MM11E-00017 WAS NOT PERFORMED IT WILL NOT BE NECESSARY TO IMPLEMENT CORRECTION (1) OF THIS ECO.

APPROVAL

DESIGN ENGINEER P DURANT 3/2/71 ENG MGR _____

PRODUCTION ENGINEER DON CALL 3/3/71 FIELD SERVICE (ADVISORY) J. BUZYNSKI

CHIEF ENGINEER _____

**ENGINEERING CHANGE ORDER
DOCUMENT & MATERIAL**

ECO NO
MM11E-00020
Sheet 2 of 3

ITEM	DOCUMENT/OR PART NUMBER	OLD REV	NEW REV	(PART NAME) DESCRIPTION OF CHANGE	DISP CODE
1	A-ML-MM11-E	T	U	(MASTER LIST) UPDATE REVISION LEVEL OF ITEM 3 THIS ECO	06
2	A-ML-MM11-EX	-	A	(MASTER LIST) SAME CHANGE AS ITEM 1 THIS ECO	06
3	A-SP-MM11E-11	A	B	(TEST PROCEDURE) SHEET 4 OF 5: DELETE 220 NS IN PARAGRAPH 11.0 ADD 210 NS DELETE -5.3V IN PARAGRAPH 12.0 ADD -5.2V UPDATE REVISION LEVEL ON ALL SHEETS	06

DISPOSITION CODES

Use up Present Stock	01	Retrofit to Break in	06
Use Present Stock until New Stock Available	02	Documentation Change Only	06
Rework all Material	03	New Item Purchase	07
Rework until New Stock Available	04	New Item in Stock	08
		New Item on Order	09
		Return	00

FIELD SERVICE NOTES:

ECO MM11E-00020
Page 3 of 3

C LEVEL OF URGENCY code

The ECO number will be posted to the EDP file with this LOU code replacing the lead # - "A" = Mandatory, High Priority
"B" = Mandatory "C" = Applicable if symptoms are present
"D" = Low Priority "D" = Product Improvement, Optional

Yes This ECO is NO CHARGE TO CUSTOMER - All DEC installation labor and materials are to be reported under a "W" charge code.

No This ECO is STANDARD APPLICABILITY - It is to be installed at no charge for warranty and maintenance contract customers in accordance with the technical effectivity, otherwise at customer expense.
Charges - Documentation \$ N/C, Parts \$ NONE,
DEC on-site labor \$ N/C. (minimum per call billing applies)
(* parts prices not available at the time of Speco release)

F FIELD DISTRIBUTION CODE

"F" = Immediate Speco distribution to all field offices
"DF" = No general Speco distribution, only to offices where equipment is located (less than 25 units in the field)

No UNCONDITIONAL ECO - General distribution kits will include Field Installation Orders, Specos, Prints, and Parts.

Yes CONDITIONAL ECO - General distribution will include Field Installation Orders only. Prints and parts must be ordered from FSIC as required.

No Parts availability delay expected _____.

Yes The REQUIREMENT TO MEET SPECIFICATION is applicable retroactively to equipment in the field.

NOTE:



ENGINEERING
CHANGE ORDER 8523

ORIGINATOR Richard Manion 5-2
TEL EXT 2005 DATE 3/13/72
DISC PROJ NO 11 07602
COST CENTER NO 392 AF

ECO NO MM11E-00022
SHEET 1 OF 3
DATE RECEIVED 3-16-72
FIRST ISSUE 3-20-72
FINAL ISSUE

PROBLEM
Under some conditions when other options are placed along side an MM11/E they fail to operate correctly.

UNIT TO BE CHANGED

MM11/E
Memory

DISP CODE *

CORRECTION
Install a module protection plate.

OPTIONS AFFECTED

MM11/E

BREAK IN EFFECTIVITY
*Install module protection plate only when problems occur.

PRODUCT LINES
AFFECTED

PDP11/20

ITEM NO	DOCUMENT PART NO	OLD REV	NEW REV	DISP CODE	DESCRIPTION OF CHANGE	DOCUMENTATION AFFECTED
1.	C-DI-MM11-E-01	D	E	06	(Drawing Index Memory) Change per this ECO.	<input type="checkbox"/> MODEL <input type="checkbox"/> DIAGNOSTICS <input type="checkbox"/> TECH MANUAL <input type="checkbox"/> TESTER <input type="checkbox"/> TEST PROG <input type="checkbox"/> TOOLING <input type="checkbox"/> PKG INST <input type="checkbox"/> ENG SPEC <input type="checkbox"/> PURCH SPEC
2.	7408490	-	-	07	(Module Protection Plate) Add quantity of 1 to drawing index.	<input type="checkbox"/> FIELD SERVICE AFFECTED <input checked="" type="checkbox"/> YES <input type="checkbox"/> NO <input type="checkbox"/> Customer Change <input checked="" type="checkbox"/> Product Line Change
3.	A-ML-MM11-E	V	W	06	Update per item 1.	TYPE OF CHANGE <input type="checkbox"/> ELECTRICAL <input checked="" type="checkbox"/> MECHANICAL <input type="checkbox"/> MODULE ORDER PR MODEL <input type="checkbox"/> YES <input checked="" type="checkbox"/> NO

DISPOSITION CODES

APPROVAL SIGNATURES

00 - RETURN TO STOCK
01 - DELETED
02 - USE PRESENT STOCK UNTIL NEW STOCK AVAILABLE (PHASE IN)
03 - REWORK IMMEDIATELY (RETROFIT)
04 - DELETED
05 - DELETED
06 - DOCUMENT CORRECTION
07 - NEW ITEM (THIS ASSEMBLY)
08 - NEW ITEM (THIS COMPANY)
09 - SCRAP IMMEDIATELY

DESIGN ENGR Pete Duxin / [Signature]
ENG MGR (OPT)
FIELD SERVICE (OPT)
CHIEF ENGR (MULTI-PURPOSE) [Signature]



FIELD CHANGE ORDER

7527

FCO MM11E D0022
PAGE 1 OF 1

DATA PROCESSING AND DEC ECO LOG WILL POST THIS FCO WITH THE LEVEL OF URGENCY CODE REPLACING THE LEADING ZERO.

FIELD EFFECTIVITY

MM11-E Memory Assembly

FIELD RETROFIT IS ANTICIPATED IN 5 % OF UNITS DEFINED ABOVE

NO CHARGE TO CUSTOMER ALL DEC INSTALLATION LABOR AND MATERIAL ARE TO BE REPORTED UNDER A "W" CHARGE CODE

STANDARD APPLICABILITY THIS FCO IS TO BE INSTALLED AT NO CHARGE FOR WARRANTY AND MAINTENANCE CONTRACT CUSTOMERS IN ACCORDANCE WITH THE TECHNICAL EFFECTIVITY ABOVE OTHERWISE AT CUSTOMER EXP. USE

DOCUMENTATION \$ _____ PARTS \$ _____ DEC ON-SITE LABOR \$ _____

DEC'S MINIMUM BILLING APPLIES IF THIS FCO IS INSTALLED BY DEC THE DEC LABOR CHARGE ASSUMES FCO INSTALLATION DURING REGULAR WORKING HOURS. IF INSTALLATION OUTSIDE OF REGULAR WORKING HOURS IS ORDERED DEC'S LATEST SCHEDULE OF HOURLY RATES WILL APPLY

FIELD OFFICE FCO DISTRIBUTION CODE

F IMMEDIATE FCO DISTRIBUTION TO ALL DEC FIELD OFFICES
 DE IMMEDIATE FCO DISTRIBUTION TO REGIONAL PRODUCT SUPPORT AND TO OFFICES WHERE SUBJECT EQUIPMENT IS LOCATED

FCO KIT DISTRIBUTION

FSC WILL INITIATE DISTRIBUTION OF FCO KITS AS DEFINED BELOW IN ACCORDANCE WITH THE EDP CONFIGURATION FILE

~~FSC WILL INITIATE DISTRIBUTION OF FCO KITS AS DEFINED BELOW IN ACCORDANCE WITH THE EDP CONFIGURATION FILE~~
KITS AS DEFINED BELOW MAY BE ORDERED AS REQUIRED

CONTENTS OF AN FSC INITIATED KIT

FCO	FCO	PRINTS	PARTS

FSC INITIATED FCO KITS WILL BE DISTRIBUTED FOR ALL UNITS LISTED ON THE EDP CONFIGURATION FILE WITH THE FOLLOWING SERVICE STATUS CODES

CONTENTS OF A FIELD ORDERED KIT

FCO	FCO	PRINTS	PARTS
	X	X	X

D	H	A	W		
---	---	---	---	--	--

PRINT CHANGES ARE MINOR AND ARE TO BE MADE MANUALLY IN RED AND GREEN. FCO REVISED PRINTS WILL BE SUPPLIED ONLY UPON SPECIAL REQUEST

INSTALLATION AND TEST PROCEDURES

- Carefully install module protection plate per FCO instructions. This requires insertion of the plate under existing wire runs which are easily broken.
- Run maindecs or other programs whose failure indicated the need for this FCO to be implemented. They should now function correctly.

LEVEL OF URGENCY CODE

- A MANDATORY HIGH PRIORITY
- B MANDATORY
- C HIGH PRIORITY IF SPECIFIC HARDWARE, SOFTWARE, OR SYMPTOMS ARE PRESENT
- D APPLICABLE IF SPECIFIC HARDWARE, SOFTWARE OR SYMPTOMS ARE PRESENT
- E PRODUCT IMPROVEMENT OPTIONAL LOW PRIORITY

DISPATCH PROJECT NUMBER (FOR FIELD SERVICE REPORTING)

AVAILABILITY DELAY None NO PARTS

ESTIMATED DOWNTIME FOR INSTALLATION AND TESTING 1.0 HOURS

SPECIAL TEST EQUIPMENT, TOOLS, OR SUPPLIES

LAST PREVIOUS FCO'S C020, C016, 015

RELATED OR PREREQUISITE FCO'S

- MAINDEC CHANGE
- MAINTENANCE MANUAL CHANGE
- OPERATIONAL PROGRAMS AFFECTED

VERIFY LATHIN MAINDECS

PARTS REQUIRED

Q1 71,-09490 Module Protection Plate

NOTES

FIELD SERVICE APPROVAL

Charles Dewey

CDK

1/20 3/24 (0) 3/24 75

ECO MM11E-00022 SHEET 2 OF 2
MM11F REWORK SHEET

1. LOOSEN 2 SCREWS AT POINTS A, CARE SHOULD BE USED AT ALL TIME SO, THAT NO WIRES WILL BE DAMAGED.
2. SLIDE THE FINGERS OF THE MODULE PROTECTION PLATE UNDER THE GND LUGS. THE PROTECTION PLATE SHOULD BE RIGHT AGAINST THE WIRED ASSY. FRAME, POINTS B.
3. TIGHTEN SCREWS.

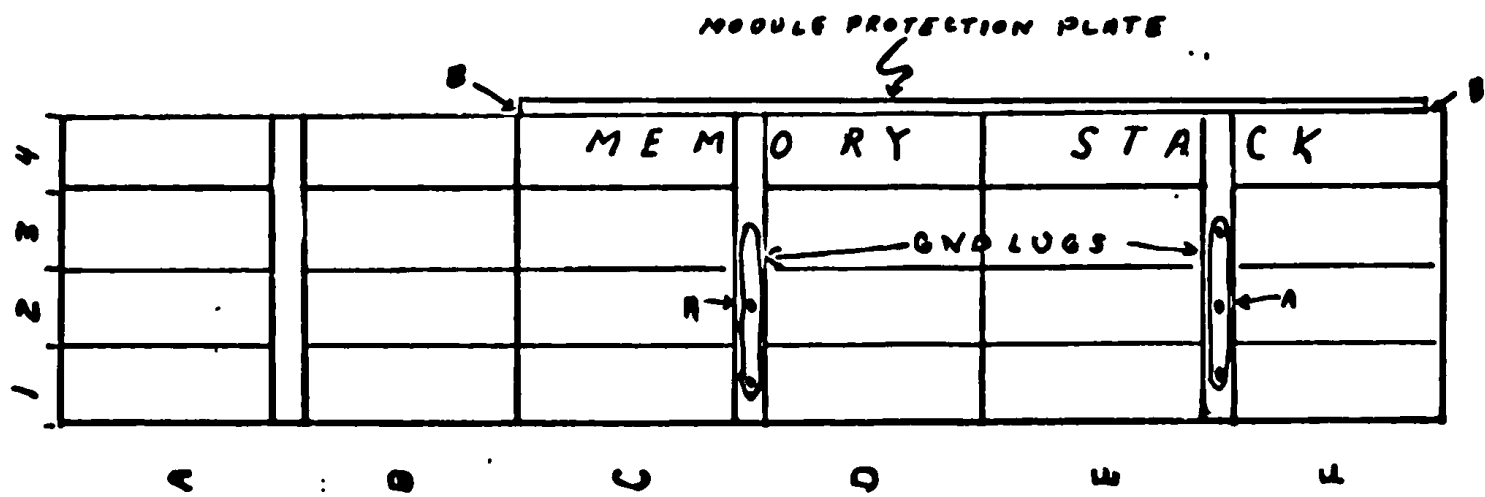

 ENGINEERING CHANGE ORDER	TITLE	DWG NO	REV
	A.N ALYCE FURTADO		
	CHK'D <i>C.H.</i>	WG LOC	GRAPHIC DESCRIPTION



ENGINEERING CHANGE ORDER

ORIGINATOR R. Manion 1-3
 TEL EXT 2005 DATE 5-6-72
 DISC PROJ NO D-96-6122
 COST CENTER NO 392

A.F.

ECO NO. MM11-0024
 SHEET 1 OF
 DATE RECEIVED 5-9-72
 FIRST ISSUE 5-11-72
 FINAL ISSUE 6-24-72

PROBLEM 1. STROBE Signals and TINH have too much noise on them.
 2. Read H signal has too many loads on it.

UNIT TO BE CHANGED
 MM11-E

DISP CODE 03

OPTIONS AFFECTED

MM11-E

CORRECTION

1. Install twisted pairs for these signals.
2. Develop another Read H signal to share the load.

BREAK IN/EFFECTIVITY All MM11-E's shipped after May 12 will have this ECO.
 Rework M729 Module when necessary, all MM11-E's shipped after May 12 will have this ECO.
 E M J Y VE M729 IS WITH ECO # 3.

PRODUCT LINES AFFECTED

PDP-11/45
 PDP-11/20
 PDP-11/45

ITEM NO	DOCUMENT/PART NO	OLD REV	NEW REV	DISP CODE	DESCRIPTION OF CHANGE
1	K-WL-MM11-E-07	D	E	06	Wire List Update
2	D-AD-7006468-0-0	D	E	06	Wire Ass'y MM11-E See final release print.
3	D-BS-MM11-E-03	A	B	06	Core Memory stack (2 sheets) See final release print.
4	A-ML-MM11-E	Z	AA	06	UPDATE REV PER THIS ECO.
5	E-DI-MM11-E-01	E	F	06	UPDATE REV PER THIS ECO
6	A-PL-7006468-0-0	D	E	06	UPDATE REV PER THIS ECO.

DOCUMENTATION AFFECTED

- MODEL
- DIAGNOSTICS
- TECH MANUAL
- TESTER
- TEST PROG
- TOOLING
- PKG INST
- ENG SPEC
- PURCH SPEC

FIELD SERVICE AFFECTED

- YES NO
- Customer Charge
- Product Line Charge

TYPE OF CHANGE

- ELECTRICAL
- MECHANICAL
- MODULE
- ORDER PR MODL
 - YES
 - NO

DISPOSITION CODES

- 00 RET JRN TO STOCK
- 01 (DELETED)
- 02 USE PRESENT STOCK UNTIL NEW STOCK AVAILABLE (PHASE IN)
- 03 REWORK IMMEDIATELY (RETROFIT)
- 04 (DELETED)
- 05 (DELETED)
- 06 DOCUMENT CORRECTION
- 07 NEW ITEM (THIS ASSEMBLY)
- 08 NEW ITEM (THIS COMPANY)
- 09 SCRAP IMMEDIATELY

APPROVAL SIGNATURES

DESIGN ENGR Pete Durant *(Handwritten Signature)*
 ENG MGR (OPT) _____
 FIELD SERVICE (OPT) _____
 CHIEF ENGR (MODULES ONLY) _____



FIELD CHANGE ORDER

FCO MM1E - **B** 0024
PAGE ___ OF ___

DATA PROCESSING AND DEC ECO-LOG WILL POST THIS FCO WITH THE LEVEL OF URGENCY CODE REPLACING THE LEADING ZERO

FIELD EFFECTIVITY
Retrofit all MM1-E's

- * LEVEL OF URGENCY CODE
- A MANDATORY HIGH PRIORITY
 - B MANDATORY**
 - C HIGH PRIORITY IF SPECIFIC HARDWARE SOFTWARE OR SYMPTOMS ARE PRESENT
 - D APPLICABLE IF SPECIFIC HARDWARE SOFTWARE OR SYMPTOMS ARE PRESENT
 - E PRODUCT IMPROVEMENT OPTIONAL LOW PRIORITY

FIELD RETROFIT IS ANTICIPATED IN 100 OF UNITS DEFINED ABOVE

- NO CHARGE TO CUSTOMER ALL DEC INSTALLATION LABOR AND MATERIAL ARE TO BE REPORTED UNDER A "W" CHARGE CODE
- STANDARD APPLX ABILITY THIS FCO IS TO BE INSTALLED AT NO CHARGE FOR WARRANTY AND MAINTENANCE CONTRACT CUSTOMERS IN ACCORDANCE WITH THE TECHNICAL EFFECTIVITY ABOVE OTHERWISE AT CUSTOMER EXPENSE
- DOCUMENTATION 8 PARTS 8 DEC ON SITE LABOR 8
- DEC'S MINIMUM BILLING APPLIES IF THIS FCO IS INSTALLED BY DEC THE DEC LABOR CHARGE ASSUMES FCO INSTALLATION DURING REGULAR WORKING HOURS IF INSTALLATION OUTSIDE OF REGULAR WORKING HOURS IS ORDERED DEC'S LATEST SCHEDULE OF HOURLY RATES WILL APPLY

DISCRETE PROJECT NUMBER (FOR FIELD SERVICE REPORTING)

AVAILABILITY DELAY	NO PARTS
PARTS	X

ESTIMATED DOWN TIME FOR INSTALLATION AND TESTING 1.0 HOURS

SPECIAL TEST EQUIPMENT, TOOLS OR SUPPLIES

FIELD OFFICE FCO DISTRIBUTION CODE

- F IMMEDIATE FCO DISTRIBUTION TO ALL DEC FIELD OFFICES
- DE IMMEDIATE FCO DISTRIBUTION TO REGIONAL PRODUCT SUPPORT AND TO OFFICES WHERE SUBJECT EQUIPMENT IS LOCATED

LAST PREVIOUS FCO'S D022, C020, C017

FCO KIT DISTRIBUTION

- PSIC WILL INITIATE DISTRIBUTION OF FCO KITS AS DEFINED BELOW IN ACCORDANCE WITH THE EDP CONFIGURATION FILE
- ~~PSIC WILL INITIATE DISTRIBUTION OF FCO KITS AS DEFINED BELOW IN ACCORDANCE WITH THE EDP CONFIGURATION FILE~~ KITS AS DEFINED BELOW MAY BE ORDERED AS REQUIRED

RELATED OR PREREQUISITE FCO'S M729-00003

- MAINDEC CHANGE
- MAINTENANCE MANUAL CHANGE
- OPERATIONAL PROGRAMS AFFECTED

CONTENTS OF AN PSIC INITIATED KIT

VIO	FCO	PRINTS	PARTS

PSIC INITIATED FCO KITS WILL BE DISTRIBUTED FOR ALL UNITS LISTED ON THE EDP CONFIGURATION FILE WITH THE FOLLOWING SERVICE STATUS CODES

CONTENTS OF A FIELD ORDERED KIT

VIO	FCO	PRINTS	PARTS
	X	X	

P	H	A	B

- PRINT CHANGES ARE MINIMAL AND ARE TO BE MADE MANUALLY IN RED AND GREEN FCO REVISED PRINTS WILL BE SUPPLIED ONLY UPON SPECIAL REQUEST

VERIFICATION MAINDECS

INSTALLATION AND TEST PARAMETERS

PARTS REQUIRED

Notes: To improve reliability on existing units.

FIELD SERVICE APPROVAL

5/11 5/17 (1534) 5/17 800

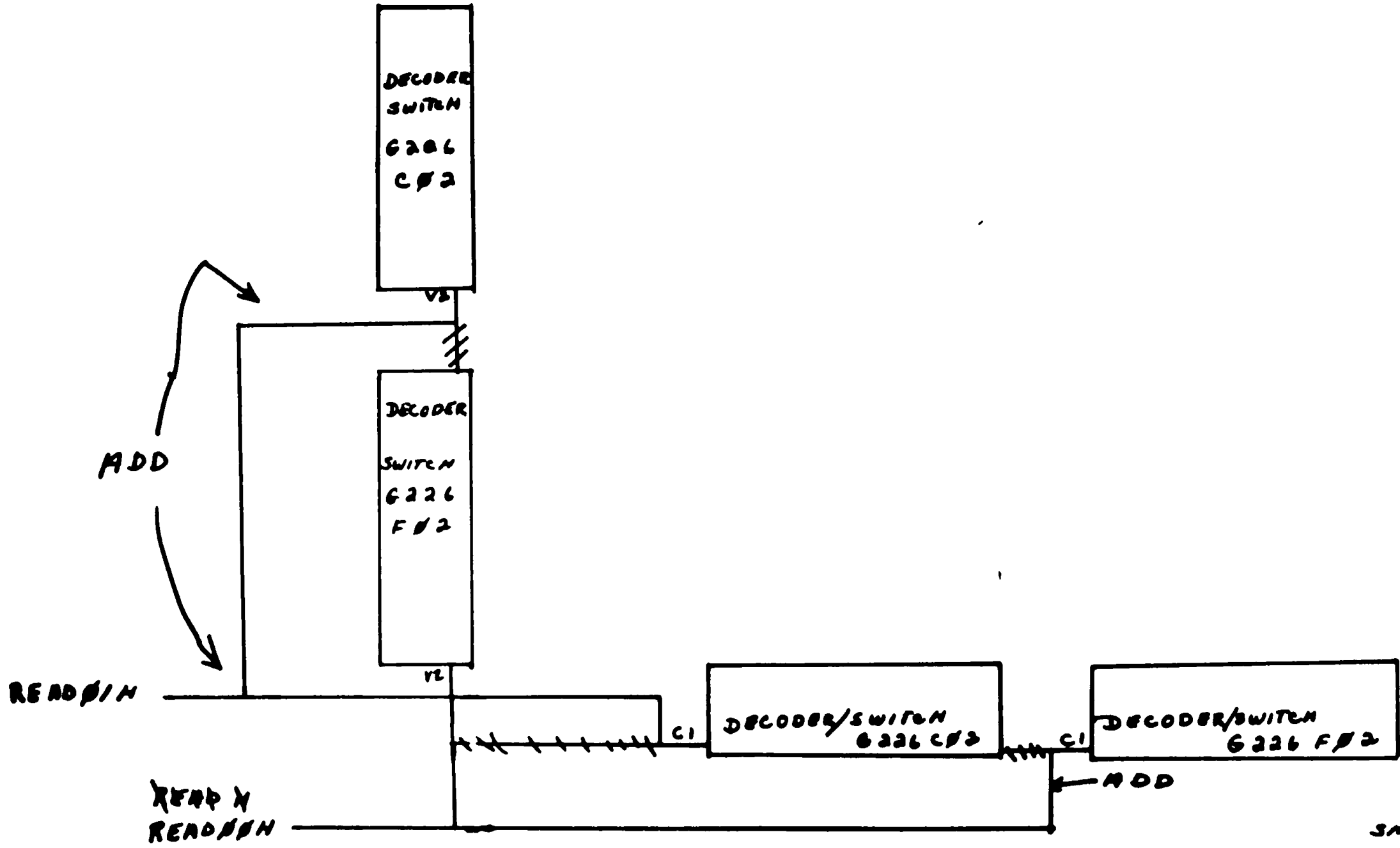

SHEET 192

digital	COMP. MEMORY STACK (X DRIVE)	ENG NO. D-05-MM11E-03	REV B
	ENGINEER NO CHANGE ORDER	DATE 1/1/68	GRAPHIC DESCRIPTION

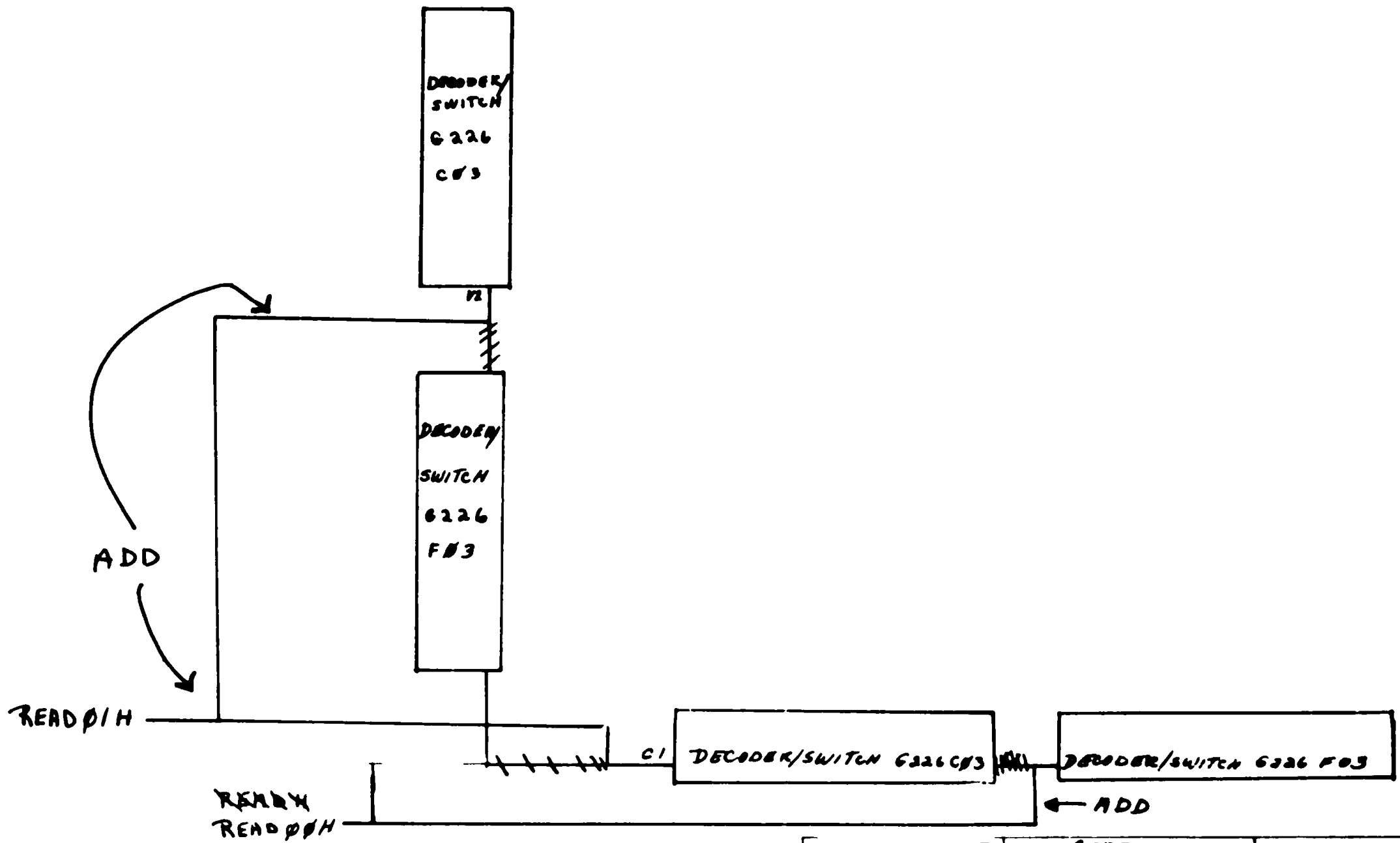

SHEET 2 of 2

	CORE MEMORY STACK (Y DRIVE) <i>Chip Switch</i>	D-BS-MM16-03	EN B
GRAPHIC DESCRIPTION			

WIRE TABLE

SIGNAL NAME	FROM PIN	TO PIN	COLOR	REMARKS	SIGNAL NAME	FROM PIN	TO PIN	COLOR	REMARKS
STROBE PH GND	CA1A1	ED2E1	WHT	TWP	TO IN H GND	EO1J1	DE2E1	WHT	TWP
	CA1C2	ED3T1	BLK			EO1C2	DE1C2	BLK	
					TI IN H GND	EO1N2	FO1E1	WHT	TWP
						EO1C2	FO1C2	BLK	
					STROBE PH GND	CO1F1	DO3S1	WHT	TWP
						CO1C2	DO2T1	BLK	

ADD

 <small>ENGINEERING CHANGE ORDER</small>	WIRED ASS'Y MM11-E	D-AD-70061AF-1-0	REV E
	BY <i>Alvin Smith</i> BY <i>Cathy</i>	GRAPHIC DESCRIPTION	

M M 1 1 - F

DOL

MM11-00001 CODE DE MI A

MAR 77 PROBLEM 1 Under some conditions when other options are present along with an MM11-F they do not operate correctly.
CORRECTION 1 Install a 1/2 inch wide protection plate.
EFFECTS 1 N/A MM11-F as required.
EFFECTS 2 N/A MM11-F as required.
Time To Install And Test 0 Hours
Kit Contents PCB Prints And Parts

MM11-00002 CODE P MI B

MAR 77 PROBLEM 1 MM11-F Test Procedure needs updating.
CORRECTION 1 Update Test Procedure.
PROBLEM 2 MM11-FX part sets are the same as MM11-F.
CORRECTION 2 Obsolete old MM11-FX Master Drawing list Use New Master Drawing list format on MM11-F to include MM11-FX.
In plant effectivity 05 documentation change only

MM11-00003 CODE F MI D WL A

MAY 77 PROBLEM 1 Strain signals and TSNM have too much noise on them.
CORRECTION 1 Install twisted pairs on strain signals generate another TSNM signal and install twisted pairs on these signals.
PROBLEM 2 RDMM signal has too many leads on it.
CORRECTION 2 Develop another RDMM signal to share the load.
CORRECTION 3 Solves memory problems caused by DMA transfers that the test diagnostics don't show up. Also solves slot sensitive L100 L102 problems.
In plant effectivity 06 Research immediately.
In plant effectivity 06 Retired on MM11-F.
Time To Install And Test 0 Hour
Kit Contents PCB Prints

FCR

MM11-F
4K 16 BIT 22 MIL MEMORY
FCO Cross Reference

**A Chronological Listing of Field Retrofit FCO's Which Must Be
Considered in the Field Installation and Maintenance of This Option/Module/Power Supply**

• Indicates FCO Conjunction Must Be Considered With Prior FCO

- | | |
|-------------------------------------------------------------------------------------------------------------------------------------------------------------------------------------------------------------------------------------------------------------------|-------------------------------------------------------------------------------------------------------------------------------------------------------------------------------------------------------------------------------------------------------------------------------------------|
| <p>1 G102 B0002 MAR 70
G102 B0003
QUICK SYNOPSIS
8881 IC s replaced by higher speed 74H011 IC s
QUICK CHECK
74H011 IC s n place of 8881 IC s
NEW REVISION
Exchange with CS B or ater</p> | <p>6 G225-C0003 JUL 70
QUICK SYNOPSIS
Speeds stab l zation of X and Y current gener ator reference voltage
QUICK CHECK
R22 changed from 4 7K ohm to 2 2K ohms
NEW REVISION
Rework etch B to CS B</p> |
| <p>2 G103 C0002 MAR 70
QUICK SYNOPSIS
Increases system speed
QUICK CHECK
7410 IC replaced by 74H10
NEW REVISION
Rework etch B C to CS B</p> | <p>7 M930-C0001 AUG 70
QUICK SYNOPSIS
Power Fail requ res BUS SP1 and BUS SP2 for AC LO and DC LO (In plant new etch B at CS A)
QUICK CHECK
R57 and R69 are 390 ohms
NEW REVISION
Exchange w th etch B</p> |
| <p>3 G103 C0004 APR 70
QUICK SYNOPSIS
Provides new higher value trimpot
QUICK CHECK
R17 changed from 100 ohm to 500 ohm trimpot
NEW REVISION
Rework etch B C to CS C</p> | <p>• 5408475-C0006 OCT 70
QUICK SYNOPSIS
AC LO and DC LO return high after assertion in multiple box systems
QUICK CHECK
D003 clamping d ode from AC LO (anode) and from DC LO to +5V line
NEW REVISION
Rework etch A B C to CS D</p> |
| <p>4 G102 B0004 JUN 70
QUICK SYNOPSIS
Decreases Turn off time of the 2007 transistors
QUICK CHECK
C2 C7 C12 C17 changed from 1000mmfd to 820mmfd
NEW REVISION
Rework etch D to CS D</p> | <p>8 M729-C0002 JAN 71
QUICK SYNOPSIS
Reduces memory cycle time on systems with 8K interleaved memory (In plant new etch C)
QUICK CHECK
W re ADD E9 pin 2 to feed thru near E5 pin 1
NEW REVISION
Rework etch B to CS B</p> |
| <p>5 G103 C0005 JUN 70
QUICK SYNOPSIS
Provides ncrease to 6 84VDC for Sense ampl fiers
QUICK CHECK
Heat sink ADD ed to Q4 C1 and C2 changed from 1000mmfd to 820mmfd
NEW REVISION
Rework etch D E to CS D</p> | |

**MM11-F
4K 16 BIT 22 MIL MEMORY
FCO Cross Reference**

**A Chronological Listing of Field Retrofit FCO's Which Must Be
Considered in the Field Installation and Maintenance of This Option/Module/Power Supply**

• Indicates FCO Conjunction Must Be Considered With Prior FCO

- | | |
|------------------------------------------------------------------------------------------------------------------------------------------------------------------------------------------------------------------------------------------------------------|----------------------------------------------------------------------------------------------------------------------------------------------------------------------------------------------------------------------------------------------------------------------------------------|
| <p>9 M1091 C0001 MAR 71
QUICK SYNOPSIS
Provides 1 unit load on BUS in systems with
16K or more memory
QUICK CHECK
M1091 rep aces M109 module
NEW REVISION
Rework etch B to CS A</p> | <p>14 MM11F-C0003 MAY 72
QUICK SYNOPSIS
Reduces noise on TINH and strobe signals
QUICK CHECK
C01C1 to D02E1/C01C2 to D02C2
NEW REVISION
Rework to Wire L st A</p> |
| <p>10 G102 B0006 APR 71
QUICK SYNOPSIS
Eliminates MM11 F's noise susceptib ity
QUICK CHECK
C3 C8 C13 C18 changed from 33mmfd to
120mmfd
NEW REVISION
Rework etch D to CS D</p> | <p>15 M729 C0003 MAY 72
M729-D0004
QUICK SYNOPSIS
Unibus hangs with SSYN asserted from
memory
QUICK CHECK
Wire ADD E5 pin 6 to E3 pin 1
NEW REVISION
Rework etch B C to CS C</p> |
| <p>11 G225-C0007 MAY 71
QUICK SYNOPSIS
Prevent heat sink from shorting to etch
QUICK CHECK
Insulating washers under heat sinks</p> | <p>16 M7290 C0003 MAY 72
QUICK SYNOPSIS
Reduced inductance of TINH H etch corrects
noise condit on (In plant new etch F)
QUICK CHECK
Wire ADD E11 pin 8 to feed thru going to
AR1
NEW REVISION
Rework etch C D to CS E</p> |
| <p>12 M7290-C0002 OCT 71
QUICK SYNOPSIS
Prevents Unibus hang with SSYN asserted
from memory (In plant new etch E)
QUICK CHECK
Wire ADD E8 p n 5 to E7 pin 9
NEW REVISION
Rework etch C to CS D</p> | |
| <p>13 MM11F D0001 MAR 72
QUICK SYNOPSIS
Module protection plate prevents MM11 F
noise interaction with adjacent modules
QUICK CHECK
Presence of protection plate</p> | |

FECOS



ENGINEERING
CHANGE ORDER *8524*

ORIGINATOR Richard Manior *5-2*
TEL EXT 2005 DATE 3/13/72
DISC PROJ NO 11 07602
COST CENTER NO 392

J.S.

ECO NO *MM11/F-0001*
SHEET *1* OF *3*
DATE RECEIVED *3-16-72*
FIRST ISSUE *3-20-72*
FINAL ISSUE

PROBLEM
Under some conditions when other options are placed along side an MM11/F they fail to operate correctly.

UNIT TO BE CHANGED
MM11/F
Memory
DISP CODE *

CORRECTION
Install a module protection plate.

OPTIONS AFFECTED
MM11/F

BREAK IN/EFFECTIVITY
*Install module protection plate only when problems occur.

PRODUCT LINES AFFECTED
PDP11/20

ITEM NO	DOCUMENT PART NO	OLD REV	NEW REV	DISP CODE	DESCRIPTION OF CHANGE
1.	A-PL-MM11-F-0	0	A	06	(Memory Assembly MM11/F) Change per this ECO.
2.	7408490	-	-	07	(Module Protection Plate) Add quantity of 1 to drawing index.
3.	A-ML-MM11-F	0	A	06	Update per item 1.

DOCUMENTATION AFFECTED

MODEL

DIAGNOSTICS

TECH MANUAL

TESTER

TEST PROG

TOOLING

PKG INST

ENG SPEC

PURCH SPEC

FIELD SERVICE AFFECTED

YES NO

Customer Charge

Product Line Charge

TYPE OF CHANGE

ELECTRICAL

MECHANICAL

MODULE

ORDER PR MODEL

YES

NO

DISPOSITION CODES

00	RETURN TO STOCK
01	(DELETED)
02	USE PRESENT STOCK UNTIL NEW STOCK AVAILABLE (PHASE IN)
03	REWORK IMMEDIATELY (RETROFIT)
04	(DELETED)
05	(DELETED)
06	DOCUMENT CORRECTION
07	NEW ITEM (THIS ASSEMBLY)
08	NEW ITEM (THIS COMPANY)
09	SCRAP IMMEDIATELY

APPROVAL SIGNATURES

Typ: *Printed* / *Handwritten* Signature

DESIGN ENGR *Pete Dwyer*

ENG MGR (OPT) _____

FIELD SERVICE (OPT) _____

CHIEF ENGR (MODULES ONLY) _____

ECU MMIF
MMIF REWORK SHEET

SHEET 2 OF 3

1. LOOSEN 2 SCREWS AT POINTS A, CARE SHOULD BE USED AT ALL TIME SO THAT NO WIRES WILL BE DAMAGED.
2. SLIDE THE FINGERS OF THE MODULE PROTECTION PLATE UNDER THE GND LUGS. THE PROTECTION PLATE SHOULD BE RIGHT AGAINST THE WIRED ASSY. FRAME, POINTS B.
3. TIGHTEN SCREWS.

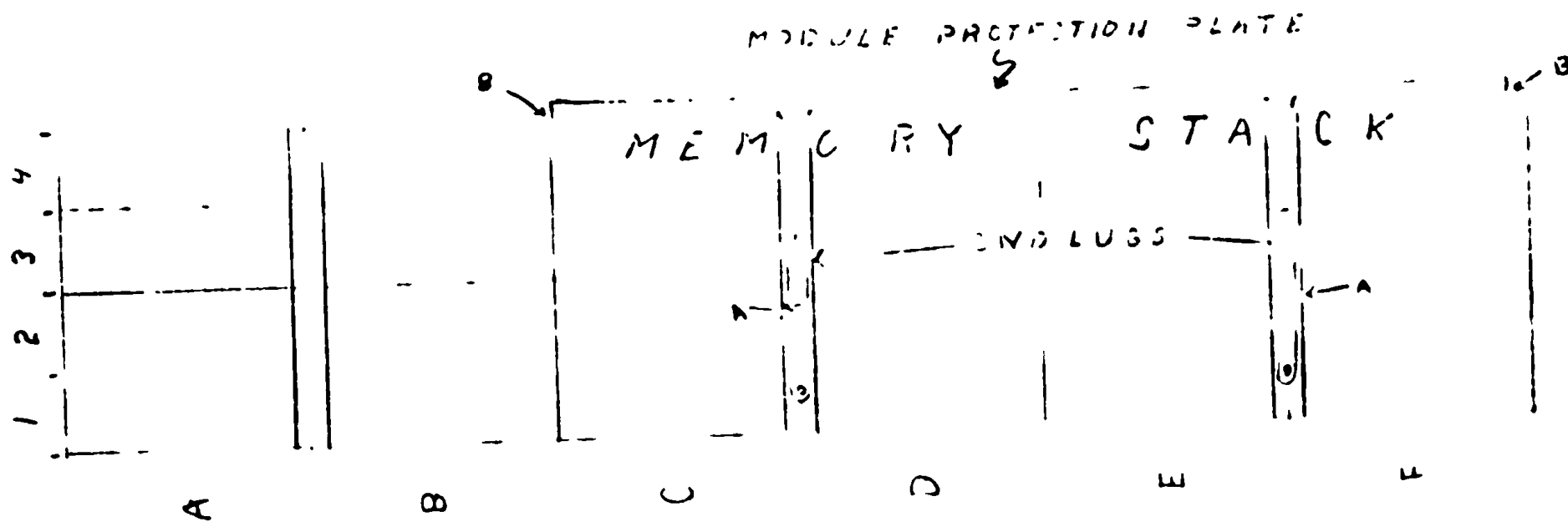



FIELD CHANGE ORDER

FCO MM11F - D 0001
PAGE 1 OF 3

DATA PROCESSING AND DEC ECO LOG WILL POST THIS FCO WITH THE LEVEL OF URGENCY CODE REPLACING THE LEADING ZERO.

LEVEL OF URGENCY CODE

- A MANDATORY HIGH PRIORITY
- B MANDATORY
- C HIGH PRIORITY IF SPECIFIC HARDWARE SOFTWARE, OR SYMPTOMS ARE PRESENT
- D APPLICABLE IF SPECIFIC HARDWARE SOFTWARE, OR SYMPTOMS ARE PRESENT
- E PRODUCT IMPROVEMENT OPTIONAL LOW PRIORITY

FIELD EFFECTIVITY
MM11-P Memory Assembly

FIELD RETROFIT IS ANTICIPATED IN _____ OF UNITS DEFINED ABOVE

NO CHARGE TO CUSTOMER ALL DEC INSTALLATION LABOR AND MATERIAL ARE TO BE REPORTED UNDER A "W" CHARGE CODE

STANDARD APPLICABILITY THIS FCO IS TO BE MADE ALL AT NO CHARGE FOR WARRANTY AND MAINTENANCE CONTRACT CUSTOMERS IN ACCORDANCE WITH THE TECHNICAL EFFECTIVITY ABOVE OTHERWISE AT CUSTOMER EXPENSE

DOCUMENTATION 8 PARTS 8 DEC ON SITE LABOR 8

DEC'S MINIMUM BILLING APPLIES IF THIS FCO IS INSTALLED BY DEC THE DEC LABOR CHARGE ASSUMES FCO INSTALLATION DURING REGULAR WORKING HOURS IF INSTALLATION OUTSIDE OF REGULAR WORKING HOURS IS ORDERED DEC'S LATEST SCHEDULE OF HOURLY RATES WILL APPLY

FIELD OFFICE FCO DISTRIBUTION CODE

- F IMMEDIATE FCO DISTRIBUTION TO ALL DEC FIELD OFFICES
- R IMMEDIATE FCO DISTRIBUTION TO REGIONAL PRODUCT SUPPORT AND TO OFFICES WHERE SUPPORT EQUIPMENT IS LOCATED

FCO KIT DISTRIBUTION

- FSC WILL INITIATE DISTRIBUTION OF FCO KITS AS DEFINED BELOW IN ACCORDANCE WITH THE EDP CONFIGURATION FILE
- FCO DISTRIBUTION TO BE INITIATED BY CUSTOMER AS DEFINED BELOW KITS AS DEFINED BELOW MAY BE ORDERED AS REQUIRED

CONTENTS OF AN FSC INITIATED KIT

FIG	FCO	PRINTS	PARTS

FSC INITIATED FCO KITS WILL BE DISTRIBUTED FOR ALL UNITS LISTED ON THE EDP CONFIGURATION FILE WITH THE FOLLOWING SERVICE STATUS CODES

CONTENTS OF A FIELD OFFICE KIT

FIG	FCO	PRINTS	PARTS
	X	X	X

I	H	A	N		
---	---	---	---	--	--

PRINT CHANGES ARE MANUAL AND ARE TO BE MADE MANUALLY IN RED AND GREEN FCO REVISED PRINTS WILL BE SUPPLIED ONLY UPON SPECIAL REQUEST

INSTALLATION AND TEST PROCEDURES

- Carefully install module protection plate per FCO instructions. This requires insertion of the plate under existing wire runs which can be easily broken.
- Run mainecs or other programs whose failures indicated the need for this FCO to be implemented. They should now function correctly.

NONE

DISPATCH PROJECT NUMBER (FOR FIELD SERVICE REPORTING)

AVAILABILITY DELAY None NO PARTS

ESTIMATED DOWN TIME FOR INSTALLATION AND TESTING 1.0 HOURS

SPECIAL TEST EQUIPMENT, TOOLS OR SUPPLIES

LAST PREVIOUS FCO'S None

RELATED OR PREREQUISITE FCO'S

- MAINDEC CHANGE
- MAINTENANCE MANUAL CHANGE
- OPERATIONAL PROGRAMS AFFECTED

VERIFICATION MAINTENANCE

PARTS REQUIRED
Q 74-08490 Module Protection Plate

FIELD SERVICE APPROVAL
Charles Dewey

CDK



ENGINEERING CHANGE ORDER #9648

ORIGINATOR Richard Manion
TEL EXT 2005 DATE 5/10/72
DISC PROJ NO 96 06122
COST CENTER NO 392

ECO NO. MM11F-00003
SHEET 1 OF
DATE RECEIVED 5-12-72
FIRST ISSUE 5-15-72
FINAL ISSUE 5-4-72

PROBLEM
1. Strobe signals and TINH have too much noise on them.
2. Read H signal has too many loads on it.
3. Solves memory problems caused by DMA transfers that memory diagnostics don't show up, also, solves slot sensitive G103, G102 problems.

UNIT TO BE CHANGED
MM11/F
DISP CODE 03

CORRECTION
1. Install twisted pairs on strobe signals, generate another TINH signal and install twisted pairs on these signals.
2. Develop another Read H signal to share the load.

OPTIONS AFFECTED
MM11/F

BREAK-IN/EFFECTIVITY
All MM11/F's shipped after May 31 will have this ECO.
Rework M7290 module when necessary, all MM11/F's with this ECO have to have M7290's with ECO #2.

PRODUCT LINES AFFECTED
PDP11/15
PDP11/20
PDP11/45

ITEM NO	DOCUMENT/PART NO	OLD REV	NEW REV	DISP CODE	DESCRIPTION OF CHANGE
1	K-WL-MM11-F-07	-	A	06	Update wire list.
2	A-PL-MM11-F-0	A	B	06	Update Rev. per this ECO.
3	A-ML-MM11-F	C	D	06	Update.
4	D-AD-7007263-0-0	-	A	06	Wire Ass'y MM11/F. See final release print.
5	D-BS-MM11-F-03	-	A	06	Core memory stack (2 sheets) See final release print.
6	A-PL-7007263-0-0	-	A	06	Update revision level.

DOCUMENTATION AFFECTED

MODEL
 DIAGNOSTICS
 TECH MANUAL
 TESTER
 TEST PROG
 TOOLING
 PKG INST
 ENG SPEC
 PURCH SPEC

FIELD SERVICE AFFECTED

YES NO
 Customer Charge
 Product Line Charge

TYPE OF CHANGE

ELECTRICAL
 MECHANICAL
 MODULE

ORDER PR MODEL
 YES
 NO

DISPOSITION CODES

00	RETURN TO STOCK
01	(DELETED)
02	USE PRESENT STOCK UNTIL NEW STOCK AVAILABLE (PHASE IN)
03	REWORK IMMEDIATELY (RETROFIT)
04	(DELETED)
05	(DELETED)
06	DOCUMENT CORRECTION
07	NEW ITEM (THIS ASSEMBLY)
08	NEW ITEM (THIS COMPANY)
09	SCRAP IMMEDIATELY

APPROVAL SIGNATURES

Typewritten / Hand Signature

DESIGN ENGR Pete Durant
ENG MGR (OPT)
FIELD SERVICE (OPT)
CHIEF ENGR (MODULES ONLY)



ENGINEERING CHANGE ORDER
ADD/DELETE SHEET

ECO NO
MM11F-00003
Sheet ___ of ___

WIRE LIST NO. K-WL-MM11-F-07

TITLE
MM11/F WIRE LIST
NEW REV A

MAKE ALL DELETIONS FIRST WHEN INSTALLING

SIGNAL NAME	FROM PIN	TO PIN	COMPONENTS	ADD	DEL
TINH H	C01C1	D02E1			X
TINH H	D03E1	E03E1			X
TINH H	E01E1	F01E1			X
STROBE 00 H	C01R1	D02S1			X
STROBE 01 H	C01A1	E01S1			X
TSS H	F01V2	F01P1			X
TINH L	C01K1	F01S1		X	
TINH L	F01S1	F01U2		X	
TINH L	F01U2	F01Y2		X	
TINH 00 H	C01C1	D02E1	WHT	TWP	X
GND	C01C2	D02C2	RED		X
TINH 01 H	F01T2	F01E1	WHT	TWP	X
GND	F01T1	F01C2	RED		X
TINH 01 H	F01T2	E02E1	WHT	TWP	X
GND	F01T1	E02C2	RED		X
STROBE 00 H	C01R1	D02S1	WHT	TWP	X
GND	C01T1	D02T1	RED		X
STROBE 01 H	C01A1	E01S1	WHT	TWP	X
GND	C01C2	E01T1	RED		X

486



FIELD CHANGE ORDER

FCO MM11F C 0003

PAGE OF

DATA PROCESSING AND DEC ECO-LOG WILL POST THIS FCO WITH THE LEVEL OF URGENCY CODE REPLACING THE LEADING ZERO

LEVEL OF URGENCY CODE

- A MANDATORY HIGH PRIORITY
- B MANDATORY
- C HIGH PRIORITY IF SPECIFIC HARDWARE, SOFTWARE, OR SYMPTOMS ARE PRESENT
- D APPLICABLE IF SPECIFIC HARDWARE, SOFTWARE, OR SYMPTOMS ARE PRESENT
- E PRODUCT IMPROVEMENT OPTIONAL LOW PRIORITY

FIELD EFFECTIVITY
Retrofit all MM11-F's

FIELD RETROFIT IS ANTICIPATED IN 100% OF UNITS DEFINED ABOVE

NO CHARGE TO CUSTOMER ALL DEC INSTALLATION LABOR AND MATERIAL ARE TO BE REPORTED UNDER A "W" CHARGE CODE

STANDARD APPLICABILITY THIS FCO IS TO BE INSTALLED AT NO CHARGE FOR WARRANTY AND MAINTENANCE CONTRACT CUSTOMERS IN ACCORDANCE WITH THE TECHNICAL EFFECTIVITY ABOVE OTHERWISE AT CUSTOMER EXPENSE

DOCUMENTATION \$ PARTS \$ DEC ON SITE LABOR \$

DEC'S MINIMUM BILLING APPLIES IF THIS FCO IS INSTALLED BY DEC THE DEC LABOR CHARGE ASSUMES FCO INSTALLATION DURING REGULAR WORKING HOURS IF INSTALLATION OUTSIDE OF REGULAR WORKING HOURS IS ORDERED, DEC'S LATEST SCHEDULE OF HOURLY RATES WILL APPLY

FIELD OFFICE FCO DISTRIBUTION CODE

- F IMMEDIATE FCO DISTRIBUTION TO ALL DEC FIELD OFFICES
- DE IMMEDIATE FCO DISTRIBUTION TO REGIONAL PRODUCT SUPPORT AND TO OFFICES WHERE SUBJECT EQUIPMENT IS LOCATED

FCO KIT DISTRIBUTION

- FSIC WILL INITIATE DISTRIBUTION OF FCO KITS AS DEFINED BELOW IN ACCORDANCE WITH THE EDP CONFIGURATION FILE
- ~~FCO KITS WILL BE DISTRIBUTED FOR ALL UNITS LISTED ON THE EDP CONFIGURATION FILE WITH THE FOLLOWING SERVICE STATUS CODES~~
KITS AS DEFINED BELOW MAY BE ORDERED AS REQUIRED

CONTENTS OF AN FSIC INITIATED KIT

FCO	PRINTS	PARTS

FSIC INITIATED FCO KITS WILL BE DISTRIBUTED FOR ALL UNITS LISTED ON THE EDP CONFIGURATION FILE WITH THE FOLLOWING SERVICE STATUS CODES

CONTENTS OF A FIELD ORDERED KIT

FCO	PRINTS	PARTS
X	X	

D	H	K	W		
---	---	---	---	--	--

PRINT CHANGES ARE MINIMAL AND ARE TO BE MADE MANUALLY IN RED AND GREEN FCO REVISED PRINTS WILL BE SUPPLIED ONLY UPON SPECIAL REQUEST

INSTALLATION AND TEST PROCEDURES

DISCRETE PROJECT NUMBER (FOR FIELD SERVICE REPORTING)

AVAILABILITY DELAY	NO PARTS
PARTS	X

ESTIMATED DOWN TIME FOR INSTALLATION AND TESTING 1.0 HOURS

SPECIAL TEST EQUIPMENT TOOLS, OR SUPPLIES

LAST PREVIOUS FCO'S D01

RELATED OR PREREQUISITE FCO'S
M7290-00003

- MAINDEC CHANGE
- MAINTENANCE MANUAL CHANGE
- OPERATIONAL PROGRAMS AFFECTED

VERIFY AT ON MAINDECS

PARTS REQUIRED

NOTES

Necessary to improve reliability on existing kits.

FIELD SERVICE APPROVAL
Art Zins

24K
5/16 5/17 (171) 5/13/10

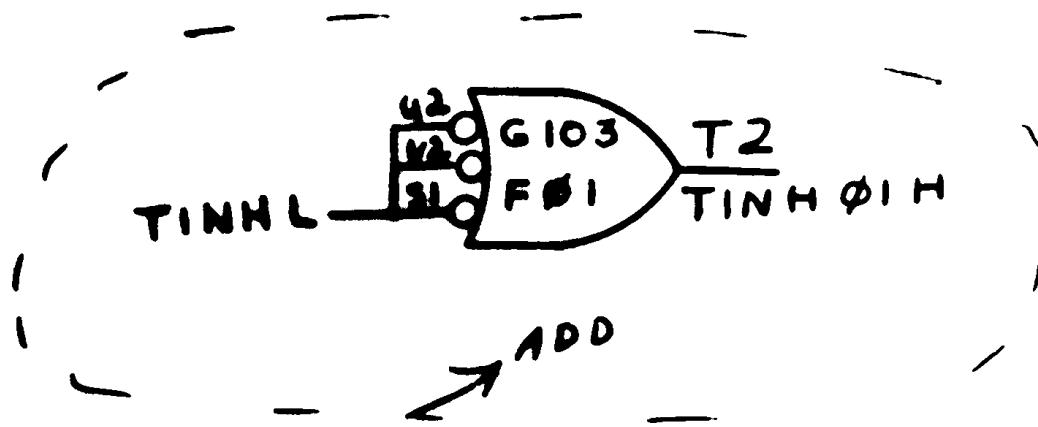

	CORE MEMORY STACK (X DRIVE)	D 05-MM11-F-03	A
	<i>Alice Hunter</i>	B-7	GRAPHIC DESCRIPTION

WIRE TABLE

SIGNAL NAME	FROM PIN	TO PIN	COLOR	REMARKS	NAME SIGNAL	FROM PIN	TO PIN	COLOR	REMARKS
-15	A03L1	F04B2	BLUE	↓ WIRES MUST PHYSICALLY RUN TO THE RIGHT OF THE BLK AND PINS					
TINN PIN GND	CP1C1 CP1C2	D03E1 D03C2	WHT BLK	TWP					
TINN PIN GND	F01T2 F01T1	F01F1 F01E2	WHT BLK	TWP	SAIB SAIB INHIB	D04V1 D04V2 D04V2	E0M2 L032 E031	WHT BLK YEL	3 TWISTED WIRES
					DIAGNOSTIC GND	CP1A1 CP1T1	D03S1 D03T1	WHT BLK	TWP
					STROBE GND	CP1A1 CP1C2	E01S1 E01T1	WHT BLK	TWP

ADD

ADD

digital

FIG 11 G
CH 61 2nd 1/2

WIRED ASSY
M 11-15

W. J. ...

DAD-707263-0-0

10 A

GRAPHIC
DESCRIPTION

M M M - L

MM11-L PARTS BREAKDOWN

G110	- Control and Data Loops
G231	- Memory Driver
H214	- 8K 16 Bit Memory Stack
MM11-L	- One 8K 16 Bit Bank of Memory

FCR

ME11 L
MEMORY BOX
FCO Cross Reference

A Chronological Listing of Field Retrofit FCO's Which Must Be
Considered in the Field Installation and Maintenance of This Option/Module/Power Supply

• Indicates FCO Conjunction Must Be Considered With Prior FCO

- 1 5409728 A0003 MAR 72
QUICK SYNOPSIS
Prevents +5V crowbar circuit damage when
F1 blows
QUICK CHECK
R52 changed from 0.2 ohms 5W to 0.1 ohms
5W
NEW REVISION
Rework etch B to CS B1
- 2 G231 B0001 MAY 72
QUICK SYNOPSIS
Prevents components on G231 shorting to
module above it
QUICK CHECK
Two phenolic 7/16 standoffs on module
NEW REVISION
Rework etch B to CS C
- 3 G110-B0005 MAY 72
QUICK SYNOPSIS
Corrects C152 insertion polarity (positive ter-
mina) to +5V
QUICK CHECK
Positive terminal of C152 tied to +5V
NEW REVISION
Rework etch C, D to CS E
- 4 G110 B0004 MAY 72
QUICK SYNOPSIS
Corrects Delay line 3 termination on etch C
G110s
QUICK CHECK
R115 changed from 3K to 1K ohms
NEW REVISION
Rework etch C to CS D
- 5 G231 D0003 AUG 72
QUICK SYNOPSIS
Improves 15V and strobe margins when
operating at 55°C
QUICK CHECK
Sixteen D672 diodes replace 330 resistors
NEW REVISION
Rework etch B to CS E
- 6 G231 A0005 AUG 72
QUICK SYNOPSIS
Improves DC LO circuitry operation
QUICK CHECK
Wire ADD from R89 to R93
NEW REVISION
Rework etch C to CS E1
- 7 5409728-C0008 SEP 72
QUICK SYNOPSIS
Increases crowbar trip voltage
QUICK CHECK
Zener changed from 5.6V to 5.7V
NEW REVISION
Rework etch C to CS C1 and etch D to CS H
- 8 G110 C0010 NOV 72
QUICK SYNOPSIS
Data errors occur during first DAT1 to any
memory bank
QUICK CHECK
Wire ADD E28 pin 13 to E15 pin 10
NEW REVISION
Rework etch C, D, E to CS J
- 9 G231 D0009 DEC 72
QUICK SYNOPSIS
G231 prints redrawn to DEC standards
NEW REVISION
CS E4
- 10 G110-D0013 DEC 72
QUICK SYNOPSIS
Ensures PAL and PBL data bits gate high onto
the Bus
QUICK CHECK
Wire ADDs E40 pin 4 to pin 13 and E40 pin 9
to pin 12
NEW REVISION
Rework etch C to CS E6

**ME11 L
MEMORY BOX
FCO Cross Reference**

**A Chronological Listing of Field Retrofit FCO's Which Must Be
Considered in the Field Installation and Maintenance of This Option/Module/Power Supply**

• Indicates FCO Conjunction Must Be Considered With Prior FCO

- | | |
|-----------------------------------------------------------------------------------------------------------------------------------------------------------------------------------------------------------------------------------------------------------------------------------------------------------------------------------------------------------------------------------------------------------------------------------------------------------------------------------------------------------------------------------------------------------------------------------------------------------------------------------------------------------------------------------------------------------------------------------------------------------------------------------------------------------------------------------------------------------------------------------------------------------------------------------------------------------------------|--------------------------------------------------------------------------------------------------------------------------------------------------------------------------------------------------------------------------------------------------------------------------------------------------------------------------------------------------------------------------------------------------------------------------------------------------------------------------------------------------------------------------------------------------------------------------------------------------------------------------------------------------------------------------------------------------------------------------------------------------------------------------------------------------------------------------------------------------------------------------------------------------------------------------------------------------------------------------------------------------------------------------------------------------------------------------------------------------------------------------------|
| <p>11 G110 D0012 DEC 72
QUICK SYNOPSIS
Provides print clarification affecting etch C
G110 s
NEW REVISION
CS E5</p> <p>12 G110 C0005 MAR 73
QUICK SYNOPSIS
Allows longer memory cycle time on systems
with high speed NPR devices
QUICK CHECK
DL3 changed from 100 nsec to 125 nsec
delay
NEW REVISION
Rework etch C to CS E7</p> <p>13 G110-C0016 MAR 73
QUICK SYNOPSIS
Eliminates noise on BUS INIT etc
QUICK CHECK
Wire ADD s E4 pin 4 to E7 pin 7 AA1 feed
thru to E7 pin 6
NEW REVISION
Rework etch C to CS E8</p> <p>14 5409728 C0010 MAR 73
QUICK SYNOPSIS
C1 and C2 holder mounting screws loosen
QUICK CHECK
1/8 spacer between holder and board adhesive
foam on each end of both capacitors
NEW REVISION
Rework etch C D E to CS K</p> | <p>15 G110 B0018 APR 73
QUICK SYNOPSIS
Eliminates noise on STROBE O H etch
QUICK CHECK
Twisted pair ADD ed E32 pin 6 of feed thru to
E58 pin 4 feed thru/E33 pin 7 to ground side
of C44
NEW REVISION
Rework etch C to CS E9</p> <p>16 5409728-E0011 JUL 73
QUICK SYNOPSIS
Corrects +5V drift with new current limiter
QUICK CHECK
R41 changed from 025 ohms to 020 ohms
7W
NEW REVISION
Exchange with CS L or later</p> <p>17 G110 C0019 NOV 73
QUICK SYNOPSIS
Welding R/W RESET L prevents memory
skipping a restore cycle
QUICK CHECK
E28 pin 8 goes to tap 10 of DL
NEW REVISION
Rework etch C to CS E10</p> <p>18 5409728 B0012 DEC 73
QUICK SYNOPSIS
Provides straps to conduct high current and
radiate heat at C7 and L1 circuit contact
points
QUICK CHECK
Presence of thermal straps at C7 and L1
NEW REVISION
Rework etch C to CS C2 etch D to CS H1
etch E to CS M</p> |
|-----------------------------------------------------------------------------------------------------------------------------------------------------------------------------------------------------------------------------------------------------------------------------------------------------------------------------------------------------------------------------------------------------------------------------------------------------------------------------------------------------------------------------------------------------------------------------------------------------------------------------------------------------------------------------------------------------------------------------------------------------------------------------------------------------------------------------------------------------------------------------------------------------------------------------------------------------------------------|--------------------------------------------------------------------------------------------------------------------------------------------------------------------------------------------------------------------------------------------------------------------------------------------------------------------------------------------------------------------------------------------------------------------------------------------------------------------------------------------------------------------------------------------------------------------------------------------------------------------------------------------------------------------------------------------------------------------------------------------------------------------------------------------------------------------------------------------------------------------------------------------------------------------------------------------------------------------------------------------------------------------------------------------------------------------------------------------------------------------------------|

**ME11 L
MEMORY BOX
FCO Cross Reference**

**A Chronological Listing of Field Retrofit FCO's Which Must Be
Considered in the Field Installation and Maintenance of This Option/Module/Power Supply**

• Indicates FCO Conjunction Must Be Considered With Prior FCO

- 19 5409728-B0017 APR 74**
QUICK SYNOPSIS
C16 overstressed in circuit application
QUICK CHECK
C16 changed from 100mfd 20V to 22mfd
35V
NEW REVISION
Rework etch C to CS C3 etch D to CS H2
etch E to CS R
- 20 5409728-B0019 MAY 74**
QUICK SYNOPSIS
Prevents overtightening of Q7 Q23 hardware
QUICK CHECK
Mounting hardware changed to 4 40 Kepnuts
NEW REVISION
Rework etch C to CS C4 etch D to CS H3
etch E to CS M3 S
- 21 5409728 B0020 MAY 74**
QUICK SYNOPSIS
5409728 used in H750 requires new thermal
strap (See FCO 5409728 B0012)
QUICK CHECK
55 10892 strap replaced with 55 11105
strap
NEW REVISION
Rework etch C to CS C5 etch D to CS H4
etch E to CS T
- 22 5409728 S0022 OCT 75**
5409728-S0023 OCT 75
QUICK SYNOPSIS
Poor performance of germanium transistors in
AC LO and DC LO circuits
QUICK CHECK
GE transistors replaced by JFET (Q14 and
Q19 are 2N5433) Two small TO18 can type
transistors replaced by TO5 cans
NEW REVISION
Rework etch C to CS C7 etch D to H6 etch E
to CS M6

ECO

QUICK

CHECK

NOV./74

MM11-L PARTS BREAKDOWN

G110	- Control and Data Loops
G231	- Memory Driver
H214	- 8K 16 Bit Memory Stack
MM11-L	- One 8K 16 Bit Bank of Memory

MM11-L FIELD CODED ECO'S

G110	B4, B5, C9, C10 & A, D12, D13 & A, C15 & A, C16, B18, C19
G231	B1, D3, A5, D9

March/75

MM11-L ECO PARTS

<u>NAME</u>	<u>ECO #</u>	<u>QTY</u>	<u>PART NUMBER</u>	<u>COMMENTS & DESCRIPTION</u>
G110	#4	1	13-00365	Resistor
	#5	1	10-05306	Capacitor
		4	90-08213	Standoffs
	#9	A/R	17-00024	#10 black/wire ground wire
	#10	1	19-05547	I.C.
	#15	1	16-11327	Delay
	#18	1	10-01610	Capacitor
G231	#1	2	90-06892	Standoffs
	#3	16	11-05275	Diode
	#15	A/R	90-09185	Jumper Wire

G110 CONTROL & DATA LOOPS				ETCH	OPTION	OPTION SERIAL #	PDP	SYSTEM SERIAL #	LOCATION	CAB	BOX	SYS. UNIT	SLOT	IPB	PAGE 1 OF 4
ECO	RELEASE DATE	CS	ETCH WL	ECO HRS. TIME	QUICK CHECK CAUTION - NOT COMPLETE ECO			QTY.	PARTS REQUIRED	MAINDECS REQUIRED	PRINT SET UPDATED	ACTUAL INSTALL TIME	DATE INSTALLED	CE NAME	
00001	03/72	A	C		R118 is a 220 ohm resistor R118 is left of E28 and right of DL3 or possibly under DL3 E28 is the 6th I.C. from BF1 DL3 is the small delay line right of DL1 DL1 is the biggest delay line				N11						
00002	03/72	B	C		DL3 is a 100n sec. delay line with part number D-10100 and/or 1609559 DL3 is a small delay line just right of LL1-08 DL1 is the biggest delay line on board <u>DL3 CHANGED TO 125 V SEC. (P/N-322-1)</u> <u>AND/OR 1611327 BY ECO #15 +15A</u>				N11						
00003	08/72	C	D		R113 is a 120 ohm 1/2W 5% resistor R113 is located at AS1 below DL2 DL2 is between E1 and E2				N11						
B 00004	08/72	D	C	1.0	<u>NOTE:</u> This ECO affects only "C" etch modules R115 is a 1K 1/2W 5% resistor R115 is the 3rd resistor right of DL1-12 DL1 is the biggest delay line			1	13-00365					DZMMG DZMMI	
B 00005	08/72	E	C	3.0	<u>NOTE:</u> This ECO affects only "C" etch modules C152 is a 6.8 ufd. capacitor with the cathode connected to the + etch on board. C152 is the capacitor right of DL1 -02 DL1 is the biggest delay line			1 4	10-05306 90-08213						

G110 CONTROL & DATA LOOPS					ETCH	OPTION	OPTION SERIAL #	PDP	SYSTEM SERIAL #	LOCATION	CAD	BOX	SYS. UNIT	SLOT	IPB	PAGE 2 OF 4
ECO	RELEASE DATE	CS	ETCH WL	ECO HRS. TIME	QUICK CHECK CAUTION - NOT COMPLETE ECO	QTY.	PARTS REQUIRED	MAINDECS REQUIRED	PRINT SET UPDATED	ACTUAL INSTALL TIME	DATE INSTALLED	CB NAME				
00006	11/72	F	E		R123 is a <u>390</u> ohm 1/4W 5% resistor R123 is the closest resistor to BS1		N11									
00007	09/72	E1	C		4 - Standoffs <u>screwed</u> on		N11									
00008	10/72	E2	C		C47 is a <u>.01</u> uf 100V 20% disc capacitor C47 is directly below E40 E40 is the 1st I.C. from CT1 DO NOT COUNT PULSE TRANSFORMER AS I.C.		N/A									
C 00009	12/72	E3	C	.5	Four #18 gauge black ground jumpers on SIDE ONE INSTEAD OF ON SIDE # TWO		17-00024 (#18 black & white teflon coated)									
C 00010 & 10A	11/72	E4	C	1.0	Jumper E15-10 to E28-13 E15 is the 4th I.C. from AV1. E28 is the 6th I.C. from BE1.	1	19-05547	DZQKB								
00011	12/72				<u>NOTE:</u> This ECO deleted		N/A									
D 00012	12/72	E5	C	N/A	<u>NOTE:</u> Print update affecting only "C" etch modules.		N11									

REVISION DATE Jan./75

G110 CONTROL & DATA LOOPS				ETCH	OPTION	OPTION SERIAL #	PDP	SYSTEM SERIAL #	LOCATION	CAB	BOX	SYS. UNIT	SLOT	IPB	PAGE 3 OF 4
ECO	RELEASE DATE	CS	ETCH WL	ECO HRS. TIME	QUICK CHECK CAUTION - NOT COMPLETE ECO			QTY.	PARTS REQUIRED	MAINDECS REQUIRED	PRINT SET UPDATED	ACTUAL INSTALL TIME	DATE INSTALLED	CB NAME	
D 00013 & 13A	01/73	E6	C	.5	NOTE: Rework only "C" etch modules Jumper pin 4 to 13 on spare I.C. slot above E40 E40 is the 1st I.C. from CT1				N11	DZQMB					
00014	03/73	K	F		NOTE: This ECO affects only CS "F" etch "E" modules Jumper E15-10 to E28-13 E15 is the 4th I.C. from AV1 E28 is the 6th I.C. from BE1				N/A						
00014A	03/73	K	F		NOTE: This ECO affects E & F etch revs modules DL3 is 125 n sec. delay line with P/N 1-322-1 and or 1611327 DL3 is small delay line right of the big delay line				N/A						
C 00015 & 15A	05/73	E7	C	1.0	NOTE: This ECO affects "C" etch rev modules DL3 is 125 n sec. delay line with P/N L-00-01 and/or 1611327 DL3 is small delay line right of the big delay line			1	16-11327	DZMMG DZQKB DZQGA					
C 00016	06/73	E8	C	2.0	NOTE: Rework only "C" etch rev modules Jumper E04-04 to E07-07				N11	DZMMG DZQKB DZQGA					
00017	12/73	L	F		NOTE: This ECO affect only "E" & "F" etch rev modules Jumper E04-04 to E07-07				N11						

CONTROL & DATA LOOP				ETCH	OPTION	OPTION SERIAL#	PDP	SYSTEM SERIAL #	LOCATION	CAB	BOX	SYS. UNIT	SLOT	IPB	PAGE 4 OF 4
G110															
ECO	RELEASE DATE	CS	ETCH WL	ECO HRS. TIME	QUICK CHECK CAUTION - NOT COMPLETE ECO	QTY	PARTS REQUIRED	MAINDECS REQUIRED	PRINT SET UPDATE	ACTUAL INSTALL TIME	DATE INSTALLED	CE NAME			
B 00018	10/73	E9	C	1.0	NOTE: Rework etch "C" Rev White wire of twisted pair from E32-06 feed through to E58-14 E32 is the 4th I.C from BS1 E58 is the 1st I.C from FC1	1	10-01610								
C 00019	12/73	E10	C	1.0	NOTE: Rework "C" etch rev Visual check of jumper or etch run from E26-08 to DL1 tap 10 (Do Not Use Meter) E26 is the 4th I.C from BE1 DL1 is the biggest delay line		NIL	DZQMB							
00020 &A	01/74	M	H		NOTE: Affects "F" etch rev Visual check of jumper or etch run from E26-08 to DL1 tap 10 (Do Not Use Meter) E26 is the 4th I.C from BE1 DL1 is the biggest delay line		N/A								
00021	07/74	N N E11 E11	H F E C		NOTE: Phase in DEC 8640's to replace DEC 380's		N/A								
00022	05/76	P	H		NOTE: DEC 7438 allowable I.C. substitution for 74H01-1 at E5, E18-E22		NIL								

G231 MEMORY DRIVER				ETCH	OPTION	OPTION SERIAL #	PDP	SYSTEM SERIAL #	LOCATION	CAB	BOX	SYS. UNIT	SLOT	IPB	PAGE 1 OF 3
ECO	RELEASE DATE	CS	ETCH	ECO HRS. TIME	QUICK CHECK CAUTION - NOT COMPLETE ECO			QTY	PARTS REQUIRED	MAINDECS REQUIRED	PRINT SET UPDATED	ACTUAL INSTALL TIME	DATE INSTALLED	CE NAME	
B 00001	6/72	C	C	3.0	Two standoffs to prevent shorting			2	90-06892						
00002	8/72	D	D		Four standoffs on module				Nil						
D 00003	8/72	E	D	4.0	NOTE: Rework only "C" etch modules D116 is a D672 diode instead of being a resistor D116 is the only diode right of E1			16	11-05275	DZMMI					
00004 & 4A	8/72	F	E		E2 is a DEC I.C. 1074H00 E2 is the I.C. closest to the top left corner.				Nil						
A 00005	8/72	E1	C	4.0	NOTE: Rework only G231's with etch rev "C" which are in 11/05 and ME11 systems. 11/45 memories do <u>not</u> need this ECO Jumper from R101 to Q7 R101 is the 3rd resistor from bottom left corner Q7 is the biggest transistor from E1				Nil						
00006	8/72	E2	C		R170 is a 100 ohm 1/4W 5% resistor R170 is the 2nd resistor from top edge of board in the 1st row of resistors left of E1				Nil						
00007	9/72	E3	C		NOTE: Print update				Nil						

G231 MEMORY DRIVER				ETCH	OPTION	OPTION SERIAL #	PDP	SYSTEM SERIAL #	LOCATION	CAD	BOX	SYS. UNIT	SLOT	IPB	PAGE 2 OF 3
ECO	RELEASE DATE	CS	ETCH NL	ECO MRS. TIME	QUICK CHECK CAUTION - NOT COMPLETE ECO				QTY	PARTS REQUIRED	MAINDECS REQUIRED	PRINT SET UPDATED	ACTUAL INSTALL TIME	DATE INSTALLED	CE NAME
00008	9/72	E1A E2A E3A	C C C		C52 is a 470 pfd 100V 5% capacitor C52 is at the far left of DR1 and the only component between two transistors					Nil					
D 00009	12/12	E4	C	N/A	NOTE: Field service clarification for etch "C" modules					Nil					
00010	3/73	H	E		E1 is a DEC I.C. 4011 quad transistor					N/A					
00011	4/73	E5	C		E1 is a DEC I.C. 4011 quad transistor					N/A					
00012	4/73	J	E		NOTE: Affects etch "E" rev only R176 is a 4.7K 1/4W 5% resistor R176 is the 1st resistor below two transistors at the far left of EJ1					N/A					
00013	11/73	K	E		NOTE: I.C. substitution cancelled by ECO # 16					N/A					
00014	2/74	L	E		Q12 as snap-on heat sink Q12 is closest transistor to bottom left corner.					N/A					
00015	6/74	M	E ALL		NOTE: This ECO affects all etch rev modules. J1 & J2 have insulated jumper wire J1 & J2 are between E31 and E34 E31 is the last I.C. from CD slot					N/A					
00016	/74	N E6	E C		NOTE: I.C. 380 and 7380 are unsuitable E9, E15, E16, E17 are I.C. DEC 8640's E9 is the last I.C. from AV1 E15 is the 1st I.C. from BF1					N/A					

G231 MEMORY DRIVER				ETCH	OPTION	OPTION SERIAL #	PDP	SYSTEM SERIAL #	LOCATION	CAB	BOX	SYG. UNIT	SLOT	IPB	PAGE 3 OF 3
ECO	RELEASE DATE	CS	ETCH WL	ECO HRS. TIME	QUICK CHECK CAUTION - NOT COMPLETE ECO	QTY	PARTS REQUIRED	MAINDECS REQUIRED	PRINT SET UPDATED	ACTUAL INSTALL TIME	DATE INSTALLED	CE NAME			
00017	01/75	P	E		Q6 is a DEC 6534C transistor Q6 is the <u>last</u> transistor from EJ1		N/A								
00018	04/75	R	E		<u>NOTE</u> : Phase in jumper wire For current loops using teflon insulated wire		N/A								

H214 - 8K x 16 BIT MEMORY STACK		ETCH	OPTION	OPTION SERIAL #	PDP	SYSTEM SERIAL #	LOCATION	CAB	BOX	SYS. UNIT	SLOT	IPB	PAGE 1 OF 1
ECO	RELEASE DATE	CS	ETCH #L	ECO HRS. TIME	QUICK CHECK CAUTION - NOT COMPLETE ECO		QTY	PARTS REQUIRED	MAINDECS REQUIRED	PRINT SET UPDATED	ACTUAL INSTALL TIME	DATE INSTALLED	CS NAME
00001	6/72	B			<u>NOTE:</u> Print change			Nil					
00002	1/73	C			<u>NOTE:</u> Reference chart for H214, H215, H216 and G645 etch & CS revs			Nil					
00003	6/73	D			<u>NOTE:</u> Allowable I.C. substitution is DEC 2501 to DEC 2501-01, 2501-02, 2501-03			N/A					
00004	10/73	E			<u>NOTE:</u> Print correction			Nil					
00005	11/73	F			<u>NOTE:</u> Print correction			Nil					
00006	/74	H			<u>NOTE:</u> Documentation update								

M M M I I L P

MM11-LP PARTS BREAKDOWN

G109	- Control & Data Loops
G231	- Memory Driver
H215	- 8K 16 Bit Memory Stack
MM11-LP	- One 8K Parity Memory Bank

ECO
QUICK
CHECK

MM11-LP PARTS BREAKDOWN

G109	- Control & Data Loops
G231	- Memory Driver
H215	- 8K 16 Bit Memory Stack
MM11-LP	- One 8K Parity Memory Bank

MAR/76

MM11-LP FIELD CODED ECO'S

G109

- C4, C6, C7, C10, C11

G231

- B1, D3, A5, D9

JAN./75

MM11-I.P ECO PARTS

<u>NAME</u>	<u>ECO #</u>	<u>QTY</u>	<u>PART NUMBER</u>	<u>COMMENTS & DESCRIPTION</u>
G109	# 3, 3A	8	10-00064	Capacitor
		4	10-01610	Capacitor
		1	13-00309	Capacitor
		5	13-05324	Resistor
G109	# 6	1	16-11327	Delay
G109	# 10	1	10-01610	Capacitor
		A/R	91-07720-09	White Wire
G231	# 1	2	90-06892	Standoffs
G231	# 3	16	11-05275	Diode
G231	# 15	A/R	90-09185	Jumper Wire
M7259	# 4	1	13-01874	Resistor
		1	13-09143-11	Resistor

G109 CONTROL & DATA LOOPS		ETCH	OPTION	OPTION SERIAL#	PDP	SYSTEM SERIAL #	LOCATION	CAB	BOX	SYS. UNIT	SLOT	IPB	PAGE 1 OF 3
ECC	RELEASE DATE	CS	ETCH WL	ECO HRS. TIME	QUICK CHECK CAUTION - NOT COMPLETE ECO		QTY	PARTS REQUIRED	MAINDECS REQUIRED	PRINT SET UPDATE	ACTUAL INSTALL TIME	DATE INSTALLED	CE NAM
00001	12/72	F	E		NOTE: New etch Rev			NIL					
00002 &A	12/72	E1	C		Standoffs are screwed on			N/A					
00003 &A	01/73	E2	C		C47 is a .01uf , 100V 20% disc capacitor C47 is directly below E40 E40 is the 1st I.C. from CT1 NOTE: DO NOT COUNT PULSE TRANSFORMER		8 4 1 5	10-000064 10-01610 13-00309 13-05324					
C 00004	01/73	E3	C	2.0	NOTE: Rework G109-YA only for parity memory Jumper from E15-10 to E28-13 E15 is the 4th I.C. from AV1 E28 is the 6th I.C. from BE1			NIL	DZMFA				
00005	05/73	K	F		NOTE: Affects etch "E" and "F" revs DL3 is 125 n sec. delay line with part number L-00-01 and/or 16-11327 DL3 is the small delay line left of E28 E28 is the 6th I.C. from BE1			NIL					
C 00006	05/73	E4	C	1.0	NOTE: Affects etch "C" revs DL3 is a 125 n sec. delay line part number L-00-01 and/or 16-11327 DL3 is a small delay line left of E28 E28 is the 6th I.C. from BE1		1	16-11327	DZMMG DZQMB				

G109 CONTROL & DATA LOOPS		ETCH	OPTION	OPTION SERIAL#	PDP	SYSTEM SERIAL #	LOCATION	CAB	BOX	SYS. UNIT	SLOT	IPB	PAGE 2 OF 3
ECO	RELEASE DATE	CS	ETCH WL	ECO HRS. TIME	QUICK CHECK CAUTION - NOT COMPLETE ECO		QTY	PARTS REQUIRED	MAINDECS REQUIRED	PRINT SET UPDATE	ACTUAL INSTALL TIME	DATE INSTALLED	CE NA
C 00007	05/73	E5	C	1.0	NOTE: Affects etch "C" rev G109 & G109-YA modules Jumper E04-04 to E07-07			NIL	DZQKB				
00008 &A	06/75	E6	C		NOTE: 1) Affects etch "C" revs. 2) Generate separate G109-YA documentation 3) Change component substitution list R96 is a 82 ohm 1/2W 5% resistor R96 is right of E44 E44 is the 2nd I.C. left of DA1			NIL					
00009	12/73	L	F		NOTE: Affects etch "E" & "F" rev - G109 and G109-YA. Jumper E04-04 to E07-07		1	10-01610					
C 00010	12/73	E7	C	1.0	NOTE: Affects etch "C" rev White jumper from E32-06 to E58-14 E32 is the 4th I.C. from BS1 E58 is the 1st I.C. from FC1		1 A/R	10-01610 91-07720-09					
C 00011	12/73	E8	C	1.0	NOTE: Rework etch "C" rev Jumper or etch run from E26-08 to tap 10 of DL1 E26 is the 4th I.C. from BE1 DL1 is the biggest delay line			NIL	DZQMB				
00012 &A	06/74	M	H		NOTE: Affects etch "F" rev Jumper E26-08 to DL1-10 E26 is the 3rd I.C. from BE1 DL1 is the biggest delay line			N/A					

G109		CONTROL & DATA LOOPS		ETCH	OPTION	OPTION SERIAL#	PDP	SYSTEM SERIAL #	LOCATION	CAB	BOX	SYS. UNIT	SLOT	IPB	PAGE 3 OF 3
ECO	RELEASE DATE	CS	ETCH WL	ECO HRS. TIME	QUICK CHECK CAUTION - NOT COMPLETE ECO			QTY	PARTS REQUIRED	MAINDECS REQUIRED	PRINT SET UPDATE	ACTUAL INSTALL TIME	DATE INSTALLED	CE NAM	
00013	07/74	E9	C		NOTE: Phase in DEC 8640 to replace DEC 380 and DEC 7380 chips.			8	19-11469						
00014	05/76	P	H		NOTE: DEC 7438 allowable I.C. substitution for 74H01-1 at E5, E18 to E22.				NIL						

G231 MEMORY DRIVER				ETCH	OPTION	OPTION SERIAL #	PDP	SYSTEM SERIAL #	LOCATION	CAB	BOX	SYS. UNIT	SLOT	IPB	PAGE 1 OF 3
ECO	RELEASE DATE	CS	ETCH #	ECO HRS. TIME	QUICK CHECK CAUTION - NOT COMPLETE ECO	QTY	PARTS REQUIRED	MAINDECS REQUIRED	PRINT SET UPDATED	ACTUAL INSTALL TIME	DATE INSTALLED	CD	MAN		
B 00001	6/72	C	C	3.0	Two standoffs to prevent shorting	2	90-06892								
00002	8/72	D	D		Four standoffs on module		Nil								
D 00003	8/72	E	D	4.0	NOTE: Rework only "C" etch modules D116 is a D672 diode instead of being a resistor D116 is the only diode right of E1	16	11-05275	DZMMI							
00004 & 4A	8/72	F	E		E2 is a LEC I.C. 1074H00 E2 is the I.C. closest to the top left corner.		Nil								
A 00005	8/72	E1	C	4.0	NOTE: Rework only G231's with etch rev "C" which are in 11/05 and ME11 systems. 11/45 memories do <u>not</u> need this ECO Jumper from R101 to Q7 R101 is the 3rd resistor from bottom left corner Q7 is the biggest transistor from E1		Nil								
00006	8/72	E2	C		R170 is a 100 ohm 1/4W 5% resistor R170 is the 2nd resistor from top edge of board in the 1st row of resistors left of E1		Nil								
00007	9/72	E3	C		NOTE: Print update		Nil								

G231 MEMORY DRIVER				ETCH	OPTION	OPTION SERIAL #	PDP	SYSTEM SERIAL #	LOCATION	CAB	BOX	SYS. UNIT	SLOT	IPB	PAGE 2 OF 3
ECO	RELEASE DATE	CS	ETCH NL	ECO HRS. TIME	QUICK CHECK CAUTION - NOT COMPLETE ECO				QTY	PARTS REQUIRED	MAINDECS REQUIRED	PRINT SET UPDATED	ACTUAL INSTALL TIME	DATE INSTALLED	CE NAME
00008	9/72	E1A E2A E3A	C C C		C52 is a 470 pfd 100V 5% capacitor C52 is at the far left of DR1 and the only component between two transistors					Nil					
D 00009	12/12	E4	C	N/A	NOTE: Field service clarification for etch "C" modules					Nil					
00010	3/73	H	E		E1 is a DEC I.C. 4011 quad transistor					N/A					
00011	4/73	E5	C		E1 is a DEC I.C. 4011 quad transistor					N/A					
00012	4/73	J	E		NOTE: Affects etch "E" rev only R176 is a 4.7K 1/4W 5% resistor R176 is the 1st resistor below two transistors at the far left of EJ1					N/A					
00013	11/73	K	E		NOTE: I.C. substitution cancelled by ECO # 16					N/A					
00014	2/74	L	E		Q12 as snap-on heat sink Q12 is closest transistor to bottom left corner.					N/A					
00015	6/74	M	E ALL		NOTE: This ECO affects all etch rev modules. J1 & J2 have insulated jumper wire J1 & J2 are between E31 and E34 E31 is the last I.C. from CD slot					N/A					
00016	/74	N E6	E C		NOTE: I.C. 380 and 7380 are unsuitable E9, E15, E16, E17 are I.C. DEC 8640's E9 is the last I.C. from AV1 E15 is the 1st I.C. from BF1					N/A					

G231 MEMORY DRIVER				ETCH	OPTION	OPTION SERIAL #	PDP	SYSTEM SERIAL #	LOCATION	CAB	BOX	SYS. UNIT	SLOT	IPB	PAGE 3 OF 3
ECO	RELEASE DATE	CS	ETCH WL	ECO HRS. TIME	QUICK CHECK CAUTION - NOT COMPLETE ECO	QTY.	PARTS REQUIRED	MAINDECS REQUIRED	PRINT SET UPDATED	ACTUAL INSTALL TIME	DATE INSTALLED	CE NAME			
00017	01/75	P	E		Q6 is a DEC 634C transistor Q6 is the <u>last</u> transistor from EJ1		N/A								
00018	04/75	R	E		<u>NOTE:</u> Phase in jumper wire For current loops using teflon insulated wire		N/A								

H215 8K x 18 BIT MEMORY STACK					ETCH	OPTION	OPTION SERIAL #	PDP	SYSTEM SERIAL #	LOCATION	CAB	BOX	SYS. UNIT	SLOT	IPB	PAGE 1 OF 1
ECO	RELEASE DATE	CS	ETCH WL	ECO HRS. TIME	QUICK CHECK CAUTION - NOT COMPLETE ECO				QTY	PARTS REQUIRED	MAINDECS REQUIRED	PRINT SET UPDATED	ACTUAL INSTALL TIME	DATE INSTALLED	CE NAME	
00001	7/73	A			NOTE: Print change											

MIMI'S

MM11-S PARTS BREAKDOWN

7008816	-Backplane Assembly
7008855-2B	-11/45 MM11 Power Cable (old)
7008909	-11/40 MM11 Power Cable (old)
7009562	-G772 System Unit Harness (new)
G110	-Control & Data Loops
G231	-Memory Drivers
H214	-8K Bank of Core Memory
BC11-A	-Unibus Cable
M920	-Unibus Jumper
MM11-S	-Single Backplane Unit

DOLL

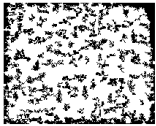

digital EQUIPMENT CORPORATION
MAYNARD MASSACHUSETTS

Engineering Change
Order Log
DEC-O-LOG

MM11-S
8K 16 Bit
890 ns Memory

23-6 R624

PROCESSOR TYPE PDP-11/45

MM11S-0001 CODE D WL A
NOTE: PR BLEM Missing wires on MM11S back plane for signal
SPGH
CORRECTION: Add bus wires to Wire List
In plant effectivity 02 remark immediately

MM11S-0002 CODE P
NOTE: CORRECTION: Make corrections to Drawing Directory BDD
MM11S
In plant effectivity 06 documentation change only

MM11S-0003 CODE F
NOTE: PROBLEM: Under some conditions when other options are
placed inside an MM11S this fail to operate correctly
CORRECTION: Install a custom module protection plate

NOTE: This PDU is required when other options such as KW1P etc are
physically mounted next to an MM11S memory. Noise generated by the
MM11S may interact with adjacent modules
In plant effectivity 02 phase in
Field effectivity: Retrofit all MM11S memories as required
Field revision B is created. Time To Install And Test 3 Hour
Kit Contents: PDU Prints And Parts

MM11S-0004 CODE P DD C
NOTE: CORRECTION: Add Manufacturing Test Procedures for MM11
K 1 M and S and drawing AN MM11 S Mem and systems to
Drawing Directory
In plant effectivity 06 documentation change only

ECO
QUICK
CHECK

MM11-S PARTS BREAKDOWN

7008816	-Backplane Assembly
7008855-2B	-11/45 MM11 Power Cable (old)
7008909	-11/40 MM11 Power Cable (old)
7009562	-G772 System Unit Harness (new)
G110	-Control & Data Loops
G231	-Memory Drivers
H214	-8K Bank of Core Memory
BC11-A	-Unibus Cable
M920	-Unibus Jumper
MM11-S	-Single Backplane Unit

JAN/75

MM11-S ECO PARTS

<u>NAME</u>	<u>ECO #</u>	<u>QTY</u>	<u>PART NUMBER</u>	<u>COMMENTS & DESCRIPTION</u>
G110	# 4	1	13-00365	Resistor
	# 5	1	10-05306	Capacitor
		4	90-08213	Standoffs
	# 9	A/R	17-00024	# 10 black/white gd.wire
	#10	1	19-05547	I.C.
	#15	1	16-11327	Delay
	#18	1	10-01610	Capacitor
G231	# 1	2	90-06892	Standoffs
	# 3	16	11-05275	Diode
	#15	A/R	90-09185	Jumper wire
MM11-S	# 3	1	74-08490	Shield

JAN./75

MM11-S FIELD CODED ECO'S

G110	B4, B5, C9, C10 & A, D12, D13 & A, C15 & A, C16, B18, C19
G231	B1, D3, A5, D9
MM11-S	C3

MM11-S 8K 16 BIT MEMORY				ETCH	OPTION	OPTION SERIAL #	PDP	SYSTEM SERIAL #	LOCATION	CAB	BOX	SYS. UNIT	SLOT	IPB	PAGE 1 OF 1
ECO	RELEASE DATE	CS	ETCH WL	ECO HRS. TIME	QUICK CHECK CAUTION - NOT COMPLETE ECO			QTY	PARTS REQUIRED	MAINDECS REQUIRED	PRINT SET UPDATED	ACTUAL INSTALL TIME	DATE INSTALLED	CE NAME	
00001	4/72		A		Jumper A01-U1 to A02-U1				Nil						
00002	9/72				<u>NOTE:</u> Print change				Nil						
C 00003	10/72			.5	A module protection plate beside MM11-S memory bank.			1	74-08490						
00004	11/72				<u>NOTE:</u> Adds test procedures for MM11-K, L, M, S and SP modules and systems				Nil						
00005	10/73				Jumper C02-A2 to F01-A2				Nil						
00006	2/74				<u>NOTE:</u> New harness (7009562) introduced for 15 pin power distribution. 11/40 and 11/45 with serial numbers greater than 6000 and 2000 respectively have a G772 system unit harness										
00007	05/75				<u>NOTE:</u> Document update										
00008	05/76				<u>NOTE:</u> Documentation update				NIL						

G110 CONTROL & DATA LOOPS		ETCH	OPTION	OPTION SERIAL #	PDP	SYSTEM SERIAL #	LOCATION	CAB	BOX	SYS. UNIT	SLOT	IPB	PAGE 1 OF 4
ECO	RELEASE DATE	CS	ETCH WL	ECO HRS. TIME	QUICK CHECK CAUTION - NOT COMPLETE ECO		QTY	PARTS REQUIRED	MAINDECS REQUIRED	PRINT SET UPDATED	ACTUAL INSTALL TIME	DATE INSTALLED	CE NAME
00001	03/72	A	C		R118 is a 220 ohm resistor R118 is left of E28 and right of DL3 or possibly under DL3 E28 is the 6th I.C. from BE1 DL3 is the small delay line right of DL1 DL1 is the biggest delay line			N11					
00002	03/72	B	C		DL3 is a 100n sec. delay line with part number 5-10100 and/or 1609559 DL3 is a small delay line just right of DL1-08 DL1 is the biggest delay line on board DL3 CHANGED TO 125 N SEC. (P/N-322-1) <u>AND/OR 1611327 BY ECO #12 +15A</u>			N11					
00003	08/72	C	D		R113 is a 120 ohm 1/4W 5% resistor R113 is located at A51 below DL2 DL2 is between E1 and E2			N11					
B 00004	08/72	D	C	1.0	NOTE: This ECO affects only "C" etch modules R115 is a 1K 1/4W 5% resistor R115 is the 3rd resistor right of DL1-12 DL1 is the biggest delay line		1	13-00365					DZMMG DZMMI
B 00005	08/72	E	C	3.0	NOTE: This ECO affects only "C" etch modules C152 is a 6.8 ufd. capacitor with the cathode connected to the + etch on board. C152 is the capacitor right of DL1 -02 DL1 is the biggest delay line		1 4	10-05306 90-08213					

REVISION DATE Jan./75

G110 CONTROL & DATA LOOPS				ETCH	OPTION	OPTION SERIAL #	PDP	SYSTEM SERIAL #	LOCATION	CAB	BOX	SYS. UNIT	SLOT	IPB	PAGE 2 OF 4
ECO	RELEASE DATE	CS	ETCH WL	ECO HRS. TIME	QUICK CHECK CAUTION - NOT COMPLETE ECO			QTY.	PARTS REQUIRED	MAINDECS REQUIRED	PRINT SET UPDATED	ACTUAL INSTALL TIME	DATE INSTALLED	CE NAME	
00006	11/72	F	E		R123 is a 390 ohm 1/2W 5% resistor R123 is the closest resistor to BS1				N11						
00007	09/72	E1	C		4 - Standoffs <u>screwed on</u>				N11						
00008	10/72	E2	C		C47 is a .01 uf 100V 20% disc capacitor C47 is directly below E40 E40 is the 1st I.C. from T1 DO NOT COUNT PULSE TRANSFORMER AS I.C.				N/A						
C 00009	12/72	E3	C	.5	Four #18 gauge black ground jumpers on SIDE ONE INSTEAD OF ON SIDE # TWO				17-00024 (#18 black & white teflon coated)						
C 00010 & 10A	11/72	E4	C	1.0	Jumper E15-10 to E28-13 E15 is the 4th I.C. from AV1. E28 is the 6th I.C. from BE1.			1	19-05547	DZQKB					
00011	12/72				<u>NOTE:</u> This ECO deleted				N/A						
D 00012	12/72	E5	C	N/A	<u>NOTE:</u> Print update affecting only "C" etch modules.				N11						

G110 CONTROL & DATA LOOPS			ETCH	OPTION	OPTION SERIAL #	PDP	SYSTEM SERIAL #	LOCATION	CAB	BOX	SYS. UNIT	SLOT	IPB	PAGE 3 OF 4
ECO	RELEASE DATE	CS	ETCH WL	ECO HRS. TIME	QUICK CHECK CAUTION - NOT COMPLETE ECO	QTY.	PARTS REQUIRED	MAINDECS REQUIRED	PRINT SET UPDATED	ACTUAL INSTALL TIME	DATE INSTALLED	CE NAME		
D 00013 & 13A	01/73	E6	C	.5	NOTE: Rework only "C" etch modules Jumper pin 4 to 13 on spare I.C. slot above E40 E40 is the 1st I.C. from CT1		N11	DZQMB						
00014	03/73	K	F		NOTE: This ECO affects only CS "F" etch "E" modules Jumper E15-10 to E28-13 E15 is the 4th I.C. from AV1 E28 is the 6th I.C. from BE1		N/A							
00014A	03/73	K	F		NOTE: This ECO affects E & F etch revs modules DL3 is 125 n sec. delay line with P/N 1-322-1 and or 1611327 DL3 is small delay line right of the big delay line		N/A							
C 00015 & 15A	05/73	E7	C	1.0	NOTE: This ECO affects "C" etch rev modules DL3 is 125 n sec. delay line with P/N L-00-01 and/or 1611327 DL3 is small delay line right of the big delay line	1	16-11327	DZMMG DZQKB DZQGA						
C 00016	06/73	E8	C	2.0	NOTE: Rework only "C" etch rev modules Jumper E04-04 to E07-07		N11	DZMMG DZQKB DZQGA						
00017	12/73	L	F		NOTE: This ECO affect only "E" & "F" etch rev modules Jumper E04-04 to E07-07		N11							

REVISION DATE MAY '76

CONTROL & DATA LOOP		ETCH	OPTION	OPTION SERIAL #	PDP	SYSTEM SERIAL #	LOCATION	CAB	BOX	SYS. UNIT	SLOT	IPB	PAGE
G110													4 OF 4
ECO	RELEASE DATE	CS	ETCH WL	ECO HRS. TIME	QUICK CHECK CAUTION - NOT COMPLETE ECO	QTY	PARTS REQUIRED	MAINDECS REQUIRED	PRINT SET UPDATE	ACTUAL INSTALL TIME	DATE INSTALLED	CE NAME	
B 00018	10/73	E9	C	1.0	NOTE: Rework etch "C" Rev White wire of twisted pair from E32-06 feed through to E58-14 E32 is the 4th I.C from BS1 E58 is the 1st I.C from FC1	1	10-01610						
C 00019	12/73	E10	C	1.0	NOTE: Rework "C" etch rev Visual check of jumper or etch run from E26-08 to DL1 tap 10 (Do Not Use Meter) E26 is the 4th I.C from BE1 DL1 is the biggest delay line		NIL	DZQMB					
00020 &A	01/74	M	H		NOTE: Affects "F" etch rev Visual check of jumper or etch run from E26-08 to DL1 tap 10 (Do Not Use Meter) E26 is the 4th I.C from BE1 DL1 is the biggest delay line		N/A						
00021	07/74	N N E11 E11	H F E C		NOTE: Phase in DEC 8640's to replace DEC 380's		N/A						
00022	05/76	P	H		NOTE: DEC 7438 allowable I.C. substitution for 74H01-1 at E5, E18-E22		NIL						

G231 MEMORY DRIVER				ETCH	OPTION	OPTION SERIAL #	PDP	SYSTEM SERIAL #	LOCATION	CAB	BOX	SYS. UNIT	SLOT	IPB	PAGE 1 OF 3
ECO	RELEASE DATE	CS	ETCH #	ECO HRS. TIME	QUICK CHECK CAUTION - NOT COMPLETE ECO			QTY.	PARTS REQUIRED	MAINDECS REQUIRED	PRINT SET UPDATED	ACTUAL INSTALL TIME	DATE INSTALLED	CE NAME	
B 00001	6/72	C	C	3.0	Two standoffs to prevent shorting			2	90-06892						
00002	8/72	D	D		Four standoffs on module				N11						
D 00003	8/72	E	D	4.0	NOTE: Rework only "C" etch modules D116 is a D672 diode instead of being a resistor D116 is the only diode right of E1			16	11-05275	DZMMI					
00004 & 4A	8/72	F	E		E2 is a DEC I.C. 1074H00 E2 is the I.C. closest to the top left corner.				N11						
A 00005	8/72	E1	C	4.0	NOTE: Rework only G231's with etch rev "C" which are in 11/05 and ME11 systems. 11/45 memories do <u>not</u> need this ECO Jumper from R101 to Q7 R101 is the 3rd resistor from bottom left corner Q7 is the biggest transistor from EL1				N11						
00006	8/72	E2	C		R170 is a 100 ohm 1/4W 5% resistor R170 is the 2nd resistor from top edge of board in the 1st row of resistors left of E1				N11						
00007	9/72	E3	C		NOTE: Print update				N11						

3231 MEMORY DRIVER				ETCH	OPTION	OPTION SERIAL #	PDP	SYSTEM SERIAL #	LOCATION	CAB	BOX	SYS. UNIT	SLOT	IPB	PAGE 2 OF 3
ECO	RELEASE DATE	CS	ETCH	ECO HRS. TIME	QUICK CHECK CAUTION - NOT COMPLETE ECO				QTY	PARTS REQUIRED	MAINDECS REQUIRED	PRINT SET UPDATED	ACTUAL INSTALL TIME	DATE INSTALLED	CE NAME
00008	9/72	E1A E2A E3A	C C C		C52 is a 470 pfd 100V 5% capacitor C52 is at the far left of DR1 and the only component between two transistors					Nil					
00009	12/12	E4	C	N/A	NOTE: Field service clarification for etch "C" modules					Nil					
00010	3/73	H	E		E1 is a DEC I.C. 4011 quad transistor					N/A					
00011	4/73	E5	C		E1 is a DEC I.C. 4011 quad transistor					N/A					
00012	4/73	J	E		NOTE: Affects etch "E" rev only R176 is a 4.7K 1/4W 5% resistor R176 is the 1st resistor below two transistors at the far left of EJ1					N/A					
00013	11/73	K	E		NOTE: I.C. substitution cancelled by ECO # 16					N/A					
00014	2/74	L	E		Q12 as snap-on heat sink Q12 is closest transistor to bottom left corner.					N/A					
00015	6/74	M	E ALL		NOTE: This ECO affects all etch rev modules. J1 & J2 have insulated jumper wire J1 & J2 are between E31 and E34 E31 is the last I.C. from CD slot					N/A					
00016	/74	N E6	E C		NOTE: I.C. 380 and 7380 are unsuitable E9, E15, E16, E17 are I.C. DEC 8640's E9 is the last I.C. from AV1 E15 is the 1st I.C. from BF1					N/A					

G231 MEMORY DRIVER		ETCH	OPTION	OPTION SERIAL #	PDP	SYSTEM SERIAL #	LOCATION	CAD	BOX	SYS. UNIT	SLOT	IPB	PAGE 3 OF 3	
ECO	RELEASE DATE	CS	ETCH #	ECO HRS. TIME	QUICK CHECK CAUTION - NOT COMPLETE ECO		QTY.	PARTS REQUIRED	MAINDECS REQUIRED	PRINT SET UPDATED	ACTUAL INSTALL TIME	DATE INSTALLED	CE NAME	
00017	01/75	P	E		Q6 is a DEC 6534C transistor Q6 is the <u>last</u> transistor from EJ1			N/A						
00018	04/75	R	E		<u>NOTE:</u> Phase in jumper wire For current loops using teflon insulated wire			N/A						

FECO'S

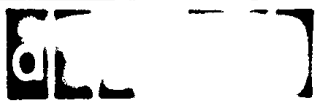
 ENGINEERING CHANGE ORDER		ORIGINATOR R. Manion 1-3 TEL EXT 2005 DATE 10/16/72 DISC PROJ NO E96A 06315 COST CENTER NO 392 W.O. 1732			ECO NO MM11S-00003 SHEET <u>1</u> OF <u>2</u> DATE RECEIVED <u>10-17-72</u> FIRST ISSUE <u>10-19-72</u> FINAL ISSUE <u>11-14-72</u>		
PROBLEM Under some conditions when other options are placed along side an MM11/S they fail to operate correctly.					UNIT TO BE CHANGED MM11/S MEMORY		
CORRECTION Install a module protection plate.					DISP CODE *02 OPTIONS AFFECTED MM11/S MM11/SP		
BREAK IN/EFFECTIVITY *Install on all units in production. Install in field if required.					PRODUCT LINES AFFECTED PDP11/45		
ITEM NO	DOCUMENT/PART NO	OLD REV	NEW REV	DISP CODE	DESCRIPTION OF CHANGE		
1.	B-DD-MM11-S	A	B	06	(Drawing Directory) Change per this ECO. (Module Protection Plate) Add D-MD-7408490-0-0 to drawing directory.	DOCUMENTATION AFFECTED <input type="checkbox"/> MODEL <input type="checkbox"/> DIAGNOSTICS <input type="checkbox"/> TECH MANUAL <input type="checkbox"/> TESTER <input type="checkbox"/> TEST PROG <input type="checkbox"/> TOOLING <input type="checkbox"/> PKG INST <input type="checkbox"/> ENG SPEC <input type="checkbox"/> PURCH SPEC FIELD SERVICE AFFECTED <input checked="" type="checkbox"/> YES <input type="checkbox"/> NO <input type="checkbox"/> Customer Charge <input checked="" type="checkbox"/> Product Line Charge TYPE OF CHANGE <input type="checkbox"/> ELECTRICAL <input checked="" type="checkbox"/> MECHANICAL <input type="checkbox"/> MODULE ORDER PR MODEL <input type="checkbox"/> YES <input checked="" type="checkbox"/> NO	
DISPOSITION CODES					APPROVAL SIGNATURES		
00 RETURN TO STOCK 01 (DELETED) 02 USE PRESENT STOCK UNTIL NEW STOCK AVAILABLE (PHASE IN) 03 REWORK IMMEDIATELY (RETROFIT) 04 (DELETED) 05 (DELETED) 06 - DOCUMENT CORRECTION 07 NEW ITEM (THIS ASSEMBLY) 08 - NEW ITEM (THIS COMPANY) 09 SCRAP IMMEDIATELY					1-3 Typewritten Hand Signature DESIGN ENGR <u>Pete Durant</u> ENG MGR (OPT) FIELD SERVICE (OPT) CHIEF ENGR (MODULES ONLY)		



FIELD CHANGE ORDER

FCO MM1S C 0003
PAGE OF

DATA PROCESSING AND DEC ECO LOG WILL POST THIS FCO WITH THE LEVEL OF URGENCY CODE REPLACING THE LEADING ZERO

* LEVEL OF URGENCY CODE

- A MANDATORY HIGH PRIORITY
- B MANDATORY
- C HIGH PRIORITY IF SPECIFIC HARDWARE SOFTWARE OR SYMPTOMS ARE PRESENT
- D APPLICABLE IF SPECIFIC HARDWARE SOFTWARE OR SYMPTOMS ARE PRESENT
- E PRODUCT IMPROVEMENT OPTIONAL LOW PRIORITY

FIELD EFFICIENCY

Retrofit all MM1-S memories as required

FIELD RETROFIT IS ANTICIPATED IN % OF UNITS DEFINED ABOVE NO CHARGE TO CUSTOMER ALL DEC INSTALLATION LABOR AND MATERIAL ARE TO BE REPORTED UNDER A "W" CHARGE CODE STANDARD APPLICABILITY THIS FCO IS TO BE INSTALLED AT NO CHARGE FOR WARRANTY AND MAINTENANCE CONTRACT CUSTOMERS IN ACCORDANCE WITH THE TECHNICAL EFFECTIVITY ABOVE OTHERWISE AT CUSTOMER EXPENSEDOCUMENTATION PARTS DEC ON SITE LABOR

DEC'S MINIMUM BILLING APPLIES IF THIS FCO IS INSTALLED BY DEC THE DEC LABOR CHARGE ASSUMES FCO INSTALLATION DURING REGULAR WORKING HOURS IF INSTALLATION OUTSIDE OF REGULAR WORKING HOURS IS ORDERED DEC'S LATEST SCHEDULE OF HOURLY RATES WILL APPLY

INQUIRY PRODUCT NUMBER W67
(FOR FIELD SERVICE REPORT NO.)AVAILABILITY DELAY None NO PARTSESTIMATED DOWN TIME FOR INSTALLATION AND TESTING 0.5 HOURS

SPECIAL TEST EQUIPMENT TOOLS OR SUPPLIES

FIELD OFFICE FCO DISTRIBUTION CODE

- F IMMEDIATE FCO DISTRIBUTION TO ALL DEC FIELD OFFICES
- IF IMMEDIATE FCO DISTRIBUTION TO REGIONAL PRODUCT SUPPORT

KIT INSTRUCTIONS

 KITS AS DEFINED BELOW MAY BE ORDERED AS REQUIRED

CONTENTS OF AN FSIC INITIATED KIT

FIO	FCO	PRINTS	PARTS	
-----	-----	--------	-------	--

FSIC INITIATED FCO KITS WILL BE DISTRIBUTED FOR ALL UNITS LISTED ON THE FDP CONF GURAT ON FILE WITH THE FOLLOWING SERVICE STATUS CODES

CONTENTS OF A FIELD ORDERED KIT

FIO	FCO	PRINTS	PARTS	
	X	X	X	

D	H	A	N		
---	---	---	---	--	--

LAST PREVIOUS FCO'S None

RELATED OR PREREQUISITE FCO'S

- MAINDEC CHANGE
- MAINTENANCE MANUAL CHANGE
- OPERATIONAL PROGRAMS AFFECTED

VERIFICATION MAINDECS

11-DZQMB

INSTALLATION AND TEST PROCEDURES

PARTS REQUIRED

Q1 74-08490 Module protection plate

NOTES This FCO is required when other options such as KW1-P, etc. are physically mounted next to an MM1-S memory. Noise generated by the MM1-S may interact with adjacent modules.

FIELD SERVICE APPROVAL

Art ZinsArt Zins10/30 450

MM115 REWORK SHEET

1. LOOSEN 2 SCREWS AT POINTS A. CARE SHOULD BE USED AT ALL TIME SO THAT NO WIRES ARE DAMAGED.
2. SLIDE THE FINGERS OF THE MODULE PROTECTION PLATE UNDER THE GND LUGS. THE PROTECTION PLATE SHOULD BE RIGHT AGAINST THE WIRED ASSY. FRAME, POINT B.
3. TIGHTEN SCREWS.

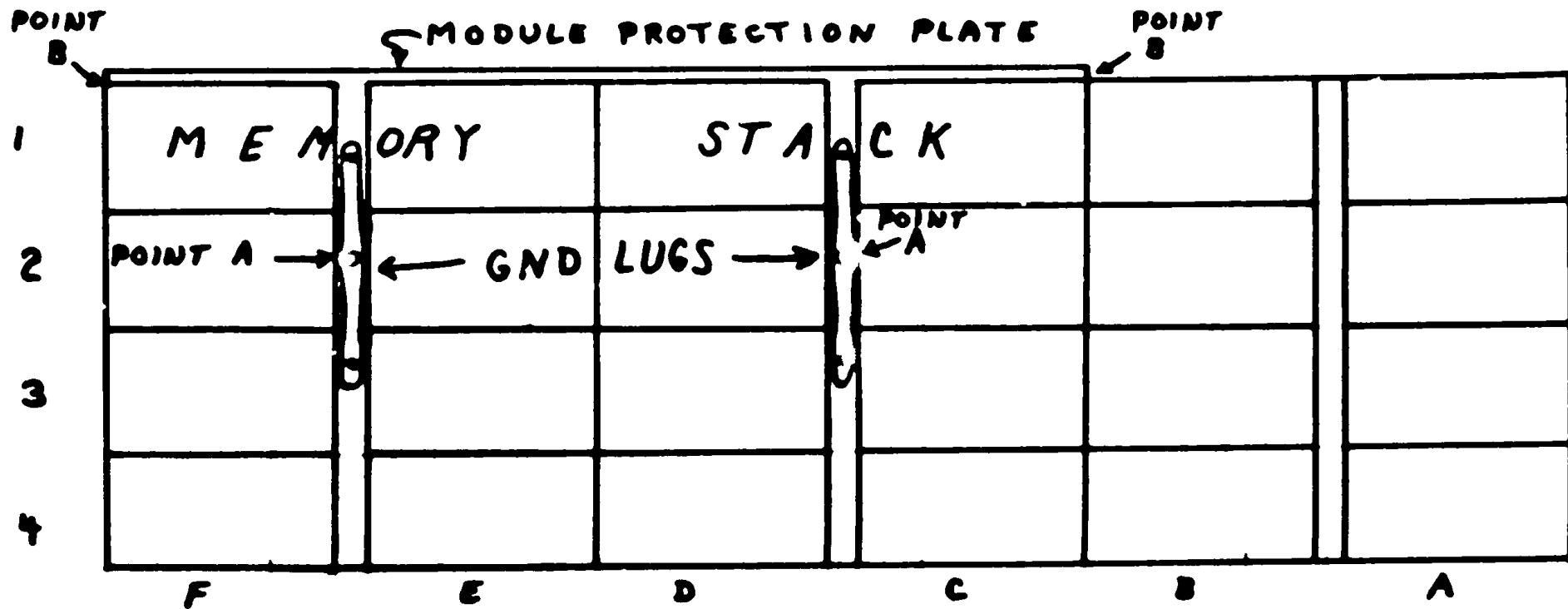

MM115-00003
Sheet 2 of 2

M M M I I - U U P

NOTE: 1) MM11-U/UP are combined together for convenience

MM11-U/UP PARTS BREAKDOWN

G114	- 16K sense memory
G235	- 16K X-Y driver
H217-C	- parity memory stack (16K X 18 bit)
H217-D	- memory stack (16K X 16 bit)
M8239	- 16K timing module
MM11-U/UP	- 16K Core Memory/Parity

MM11-U/UP FIELD CODED ECO'S

G114	- 15
G235	- 18

MM11-U/UP ECO PARTS

<u>NAME</u>	<u>ECO#</u>	<u>QTY</u>	<u>PART NUMBER</u>	<u>COMMENTS & DESCRIPTION</u>
G235	#8	1	13-00364	Resistor
		1	13-02388	Resistor

ECO

QUICK

CHECK

NOTE: 1) MM11-U/UP are combined together for convenience

MM11-U/UP PARTS BREAKDOWN

G114	- 16K sense memory
G235	- 16K X-Y driver
H217-C	- parity memory stack (16K X 18 bit)
H217-D	- memory stack (16K X 16 bit)
M8239	- 16K timing module
MM11-U/UP	- 16K Core Memory/Parity

MM11-U/UP FIELD CODED ECO'S

G114	- I5
G235	- I8

MM11-U/UP ECO PARTS

<u>NAME</u>	<u>ECO#</u>	<u>QTY</u>	<u>PART NUMBER</u>	<u>COMMENTS & DESCRIPTION</u>
G235	#8	1	13-00364	Resistor
		1	13-02388	Resistor

G114 16K SENSE INHIBIT		ETCH	OPTION	OPTION SERIAL #	PDP	SYSTEM SERIAL #	LOCATION	CAB	BOX	SYS. UNIT	SLOT	IPB	PAGE 1 OF 1
ECO	RELEASE DATE	CS	ETCH ML	ECO HRS. TIME	QUICK CHECK CAUTION - NOT COMPLETE ECO	QTY	PARTS REQUIRED	MAINDECS REQUIRED	PRINT SET UPDATED	ACTUAL INSTALL TIME	DATE INSTALLED	CE NAME	
00001	10/73	B	B		<u>NOTE:</u> Cancelled By ECO# 1A		NIL						
00001A	10/73	B	B		Gnd Jumper from FT1 and along the bottom of the board	A/R	91-07470-00						
00002	11/73	C	B		R108 is a <u>56 OHM</u> , 1/2W, 5% resistor R108 to the right of T103 T103 is a transformer along AC1 near handle side.		N/A						
00003	10/74	D	C		<u>NOTE:</u> New Etch Rev.		NIL						
00004	04/75	E	C		<u>NOTE:</u> Part substitution due to shortage		N/A						
I 00005	05/75	F	C	.5	<u>NOTE:</u> Affects only etch "C" rev's Measure open circuit from the top left metal handle to ground		NIL						

G235 16K X-Y DRIVER		ETCH	OPTION	OPTION SERIAL#	PDP	SYSTEM SERIAL #	LOCATION	CAB	BOX	SYS. UNIT	SLOT	IPB	PAGE 1 OF 2
ECO	RELEASE DATE	CS	ETC.	ECO HRS. TIME	QUICK CHECK CAUTION - NOT COMPLETE ECO		QTY	PARTS REQUIRED	MAINDECS REQUIRED	PRINT SET UPDATE	ACTUAL INSTALL TIME	DATE INSTALLED	CE NAME
00001	07/73	D	D			R35 is a 3.16K, 1/8W, 1% resistor R35 is located below W4 W4 is left of E2-01 E2 is the 2nd I.C. from AT1	1 1	13-00229 13-03045					
00002	09/73	E	D			R92 is NOT a 330ohm, 1/4W, 5% resistor R92 is the 4th component above R101 R101 is 220 ohm, 2W resistor left at AT1	1 2 1	11-03441 13-00271 13-02379					
00003	11/73	F	D			R29 is a 120K, 1/4W 5% resistor R29 is the 1st resistor above Q14 Q14 is the transistor above E4 E4 is the 2nd I.C. from BL1		N/A					
00004	01/74	H	D			D2, D3, D4 are deleted No diodes between E2 and R18 R18 is a 100ohm resistor, above E2	1 1	15-05321 19-10466					
00005	04/74	J	D			C47 is a .022 ufd capacitor C47 is the 1st capacitor below T2 T2 is a transformer at the far left of AN1	2 1	10-11683 13-04855					
00006	08/74	K	D			Delete C44 Only one 47ufd, 20V, 10% capacitor still present (not two) between Q12 and Q13 Q12 and Q13 are the 1st and 2nd transistors from AE1		NIL					

REVISION DATE MAY 1976

G235 16K X-Y DRIVER		ETCH	OPTION	OPTION SERIAL#	PDP	SYSTEM SERIAL #	LOCATION	CAB	BOX	SYS. UNIT	SLOT	IPB	PAGE 2 OF 2
ECO	RELEASE DATE	CS	ETCH WL	ECO HRS. TIME	QUICK CHECK CAUTION - NOT COMPLETE ECO		QTY	PARTS REQUIRED	MAINDECS REQUIRED	PRINT SET UPDATE	ACTUAL INSTALL TIME	DATE INSTALLED	CE NAME
00007	04/75	L	D		NOTE: Parts substitution due to shortages			NIL					
I 00008	06/75	L	D		NOTE: Must have if used on MA20-M for PDP10 R23 is an 1K 1/2W resistor R23 is the only resistor left of AA1		1 1	13-00364 13-02388					
I 00009 &A	06/76	N	J		R103 is a 75 ohm 1W 5% resistor R103 is immediately right of Q12 Q12 is the 2nd transistor from AC1								

H217 16K STACK		ETCH	OPTION	OPTION SERIAL #	PDP	SYSTEM SERIAL #	LOCATION	CAD	BOX	SYS. UNIT	SLOT	IPB	PAGE 1 OF 1
ECO	RELEASE DATE	CS	ETCH WL	ECO HRS. TIME	QUICK CHECK CAUTION - NOT COMPLETE ECO		QTY	PARTS REQUIRED	MAINDECS REQUIRED	PRINT SET UPDATED	ACTUAL INSTALL TIME	DATE INSTALLED	CB NAME
00001	05/74				<u>NOTE:</u> Manufacturing Change			NIL					
00002	07/74				<u>NOTE:</u> Document Change			NIL					
00003	10/74	B	E		<u>NOTE:</u> Rework H217-B and C (18 or 19 Bit) Diodes D29, D30 are deleted D29, D30 were Diodes left of CE1 but right of the resistor network			NIL					
00004	03/76	C	E		<u>NOTE:</u> Manufacturing change.			NIL					

REVISION DATE MAY/76

16K UNIBUS TIMING				ETCH	OPTION	OPTION SERIAL#	PDP	SYSTEM SERIAL #	LOCATION	CAB	BOX	SYS. UNIT	SLOT	IPB	PAGE 1 OF 1
ECO	RELEASE DATE	CS	ETCH WL	ECO HRS. TIME	QUICK CHECK CAUTION - NOT COMPLETE ECO			QTY	PARTS REQUIRED	MAINDECS REQUIRED	PRINT SET UPDATE	ACTUAL INSTALL TIME	DATE INSTALLED	CE NAME	
00001	10/73	B	B		NOTE: This is a mandatory ECO Measure continuity from E21-03 to E25-13 E21 is the 2nd I.C. from CL1 E25 is below E21				NIL						
00002	11/73	C	B		NOTE: This is a mandatory ECO Measure continuity from E03-05 to DL3-05 DL3 is the only delay line left of AR1				NIL						
00003 6A	06/74	D	C		NOTE: New etch rev				N/A						
00004	06/75	E	C		NOTE: Phase in DEC 8640 to replace DEC 380				N/A						
00005	06/76	F	C B		NOTE: Introduces M8293-YB for XM15 M8293-YB can be distinguished by checking for jumper from E38-12 to E38-13 E38 is the 4th I.C. from DT1				NIL						